



# Assembly manual

# CANTILEVER M



**CANTILEVER ME**



**CANTILEVER M**

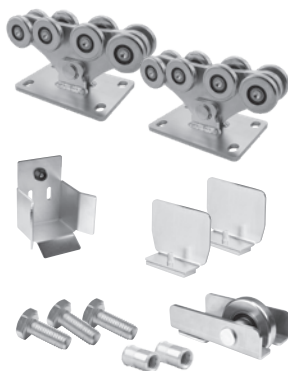

**CANTILEVER MEK**

**VITA ME 02****SET**

SPEED ME .....2 pcs  
 RUN M .....1 pc  
 LAST M .....1 pc  
 PILOT MN .....2 pcs  
 BOLT M10x25 .....15 pcs  
 RIVET NUT .....15 pcs

ART. SET / kg  
 VITA ME 02 ..... 22,5 kg

GATES UP TO  
 WEIGHT ..... 700 kg

CODE: 1710042

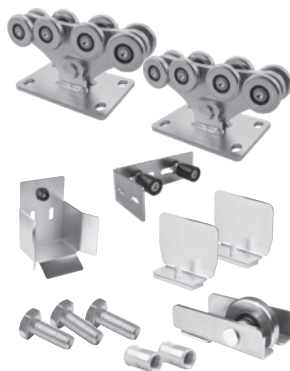
**VITA ME 03****SET**

SPEED ME .....2 pcs  
 RUN M .....1 pc  
 LAST M .....1 pc  
 PILOT MN .....2 pcs  
 FRM 2 .....1 pc  
 BOLT M10x25 .....15 pcs  
 RIVET NUT .....15 pcs

ART. SET / kg  
 VITA ME 03 .....23,7 kg

GATES UP TO  
 WEIGHT .....700 kg

CODE: 1710043

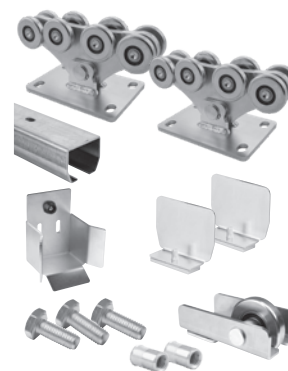
**DEMO MZE 02****SET**

SPEED ME .....2 pcs  
 STAGE MZ 6 .....1 pc  
 RUN M .....1 pc  
 LAST M .....1 pc  
 PILOT MN .....2 pcs  
 BOLT M10x25 .....15 pcs  
 RIVET NUT .....15 pcs

ART. SET / kg  
 DME0 MZE 02 ..... 87,8 kg

GATES UP TO  
 WEIGHT ..... 500 kg  
 LENGHT ..... 4 m

CODE: 1710010

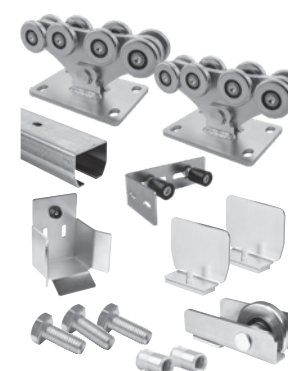
**DEMO MZE 03****SET**

SPEED ME .....2 pcs  
 STAGE MZ 6 .....1 pc  
 RUN M .....1 pc  
 LAST M .....1 pc  
 PILOT MN .....2 pcs  
 FRM 2 .....1 pc  
 BOLT M10x25 .....15 pcs  
 RIVET NUT .....15 pcs

ART. SET / kg  
 DEMO MZE 03 ..... 89,1 kg

GATES UP TO  
 WEIGHT .....500 kg  
 LENGHT ..... 4 m

CODE: 17100

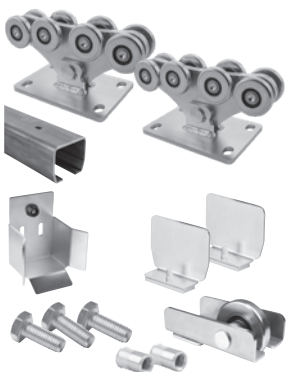
**DEMO MBE 02****SET**

SPEED ME .....2 pcs  
 STAGE MB 6 .....1 pc  
 RUN M .....1 pc  
 LAST M .....1 pc  
 PILOT SN .....2 pcs  
 BOLT M10x25 .....15 pcs  
 RIVET NUT .....15 pcs

ART. SET / kg  
 DEMO MBE 02 .....87,8 kg

GATES UP TO  
 WEIGHT .....500 kg  
 LENGHT ..... 4 m

CODE: 1710016

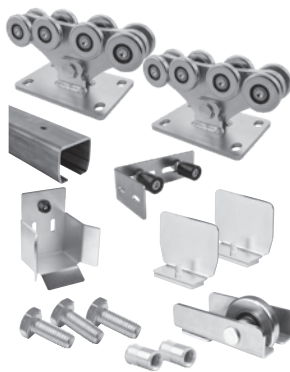
**DEMO MBE 03****SET**

SPEED ME .....2 pcs  
 STAGE MB 6 .....1 pc  
 RUN M .....1 pc  
 LAST M .....1 pc  
 PILOT MN .....2 pcs  
 FRM 2 .....1 pc  
 BOLT M10x25 .....15 pcs  
 RIVET NUT .....15 pcs

ART. SET / kg  
 DEMO MBE 03 ..... 89,1 kg

GATES UP TO  
 WEIGHT ..... 500 kg  
 LENGHT ..... 4 m

CODE: 1710052

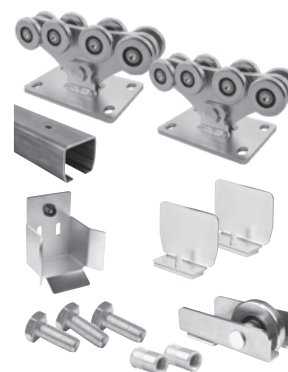
**DEMO MBE 23****SET**

SPEED ME .....2 pcs  
 STAGE MB 6 .....1 pc  
 STAGE MB 3 .....1 pc  
 RUN M .....1 pc  
 LAST M .....1 pc  
 PILOT MN .....2 pcs  
 BOLT M10x25 .....30 pcs  
 RIVET NUT .....30 pcs

ART. SET / kg  
 DEMO MBE 23 .....122,3 kg

GATES UP TO  
 WEIGHT .....600 kg  
 LENGHT ..... 6 m

CODE: 1710016

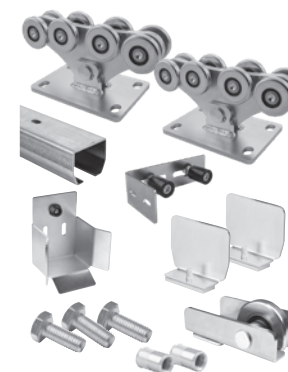
**DEMO MZE 23****SET**

SPEED ME .....2 pcs  
 STAGE MZ 6 .....1 pc  
 STAGE MZ 3 .....1 pc  
 RUN M .....1 pc  
 LAST M .....1 pc  
 PILOT MN .....2 pcs  
 FRM 2 .....1 pc  
 BOLT M10x25 .....30 pcs  
 RIVET NUT .....30 pcs

ART. SET / kg  
 DEMO MZE 23 ..... 122,3 kg

GATES UP TO  
 WEIGHT ..... 600 kg  
 LENGHT ..... 6 m

CODE: 1710073

# CAIS CANTILEVER ME

CANTILEVER ME									
	mm; kg	mm; kg	mm; kg	mm; kg	mm; kg	mm; kg	mm; kg	mm; kg	mm; kg
A	4000	4500	5000	5500	6000	6500	7000	7500	8000
max. weight gate	500 kg	525 kg	550 kg	575 kg	600 kg	625 kg	650 kg	675 kg	700 kg
B	1200	1350	1500	1650	1800	1950	2100	2250	2400
C	1860	2010	2160	2310	2460	2610	2760	2910	3060
D	330	330	330	330	330	330	330	330	330



EASY ASSEMBLING



C 2 HQ BEARINGS



FAST NO WELDING



CARRIAGES CENTER HOLES MILLED NOT LASERED



15 BOLTS 15 RIVET NUTS INCLUDED (\*)



MULTI RIVITED SECTIONS



«C» TRACK SERIAL NO. 100% COMPATIBILITY CARRIAGE TESTED



JAPANESE ROBOTICS FANUC



GERMAN STEEL WUPPERMANN



UNIVERSITY OF TECHNOLOGY - BRNO



HOT DIPPED GALVANIZED



- 37°C TESTED & PROVEN



ARROW STRAIGHT «C» TRACK



+ 50°C TESTED & PROVEN



BUILD IN FLYING HOLE PUNCH - EVERY 400 mm



NO WELDING NEEDED



GALVANIZED INTERNAL EDGES



MADE IN CZECH REPUBLIC

$$B = 0,3 \times A$$

$$L = A + B + (2 \times D) + E$$

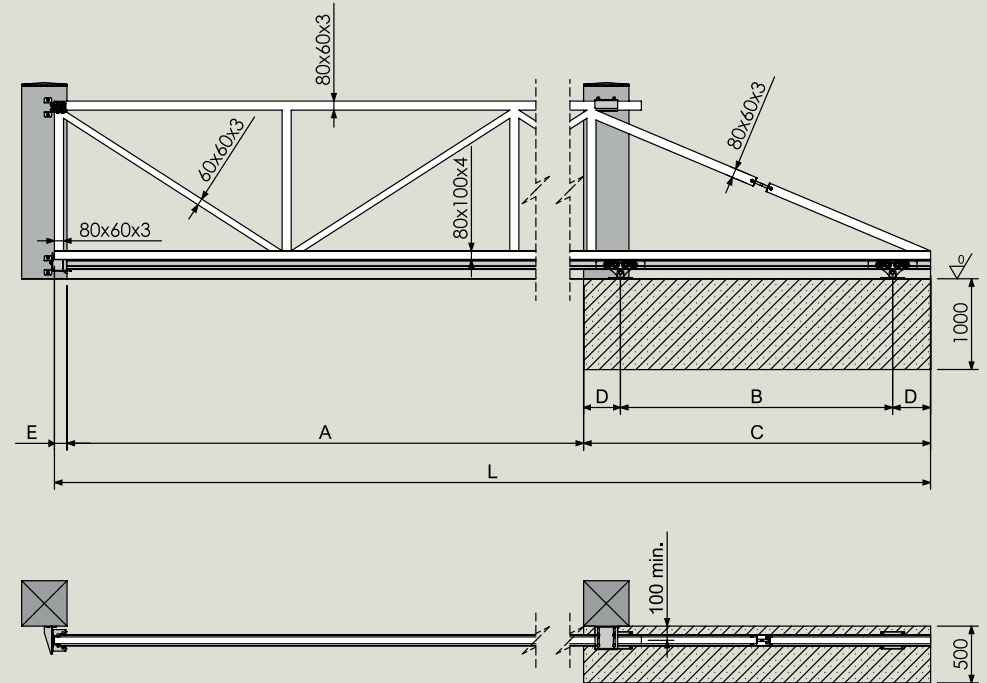
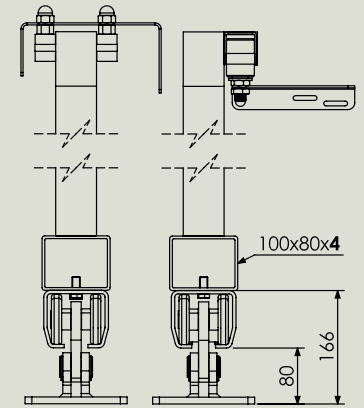

(\*) ONLY SETS

# CAIS CANTILEVER M

CANTILEVER M									
	mm; kg	mm; kg	mm; kg	mm; kg	mm; kg	mm; kg	mm; kg	mm; kg	mm; kg
<b>A</b>	4000	4500	5000	5500	6000	6500	7000	7500	8000
<b>max. weight gate</b>	500 kg	525 kg	550 kg	575 kg	600 kg	625 kg	650 kg	675 kg	700 kg
<b>B</b>	1200	1350	1500	1650	1800	1950	2100	2250	2400
<b>C</b>	1860	2010	2160	2310	2460	2610	2760	2910	3060
<b>D</b>	330	330	330	330	330	330	330	330	330



EASY ASSEMBLING



C 2 HQ BEARINGS



FAST NO WELDING



CARRIAGES CENTER HOLES MILLED NOT LASERED



15 BOLTS 15 RIVET NUTS INCLUDED (\*)



MULTI RIVETED SECTIONS



«C» TRACK SERIAL NO. 100% COMPATIBILITY CARRIAGE TESTED



JAPANESE ROBOTICS FANUC



GERMAN STEEL WUPPERMANN



UNIVERSITY OF TECHNOLOGY - BRNO



HOT DIPPED GALVANIZED



- 37°C TESTED & PROVEN



ARROW STRAIGHT «C» TRACK



+ 50°C TESTED & PROVEN



BUILD IN FLYING HOLE PUNCH - EVERY 400 mm



NO WELDING NEEDED



GALVANIZED INTERNAL EDGES



MADE IN CZECH REPUBLIC

$$B = 0,3 \times A$$

$$L = A + B + (2 \times D) + E$$

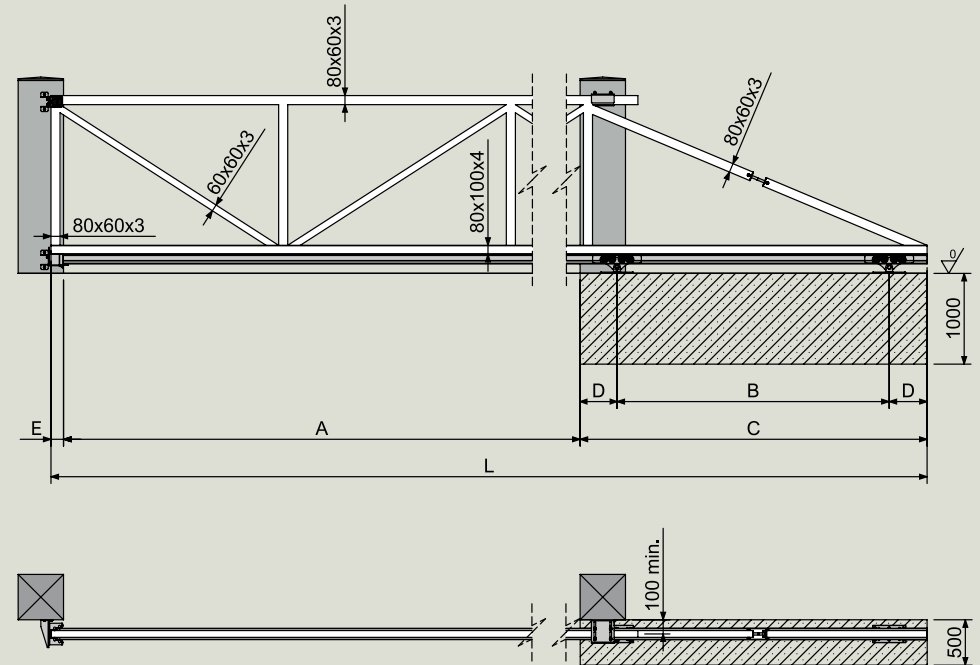
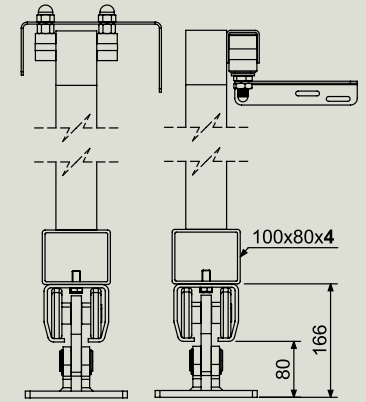

(\*) ONLY SETS



# CAIS CANTILEVER MEK

CANTILEVER MEK										
	mm; kg	mm; kg	mm; kg	mm; kg	mm; kg	mm; kg	mm; kg	mm; kg	mm; kg	mm; kg
A	4000	4500	5000	5500	6000	6500	7000	7500	8000	
max. weight gate	500 kg	525 kg	550 kg	575 kg	600 kg	625 kg	650 kg	675 kg	700 kg	
B	1200	1350	1500	1650	1800	1950	2100	2250	2400	
C	1860	2010	2160	2310	2460	2610	2760	2910	3060	
D	330	330	330	330	330	330	330	330	330	



SUITABLE FOR INCLINED SURFACE INSTALLATION



ASYMMETRIC EIGHT WHEELED CARRIAGE



EASY ASSEMBLING



C 2 HQ BEARINGS



FAST NO WELDING



CARRIAGES CENTER HOLES MILLED NOT LASERED



15 BOLTS 15 RIVET NUTS INCLUDED (\*)



MULTI RIVETED SECTIONS



«C» TRACK SERIAL NO. 100% COMPATIBILITY CARRIAGE TESTED



JPN JAPANESE ROBOTICS FANUC



D GERMAN STEEL WUPPERMANN



R&D UNIVERSITY OF TECHNOLOGY - BRNO



270 g/m<sup>2</sup> HOT DIPPED GALVANIZED



- 37°C TESTED & PROVEN



ARROW STRAIGHT «C» TRACK



+ 50°C TESTED & PROVEN



BUILT IN FLYING HOLE PUNCH - EVERY 400 mm



CZ MADE IN CZECH REPUBLIC



GALVANIZED INTERNAL EDGES



NO WELDING NEEDED

$$B = 0,3 \times A$$



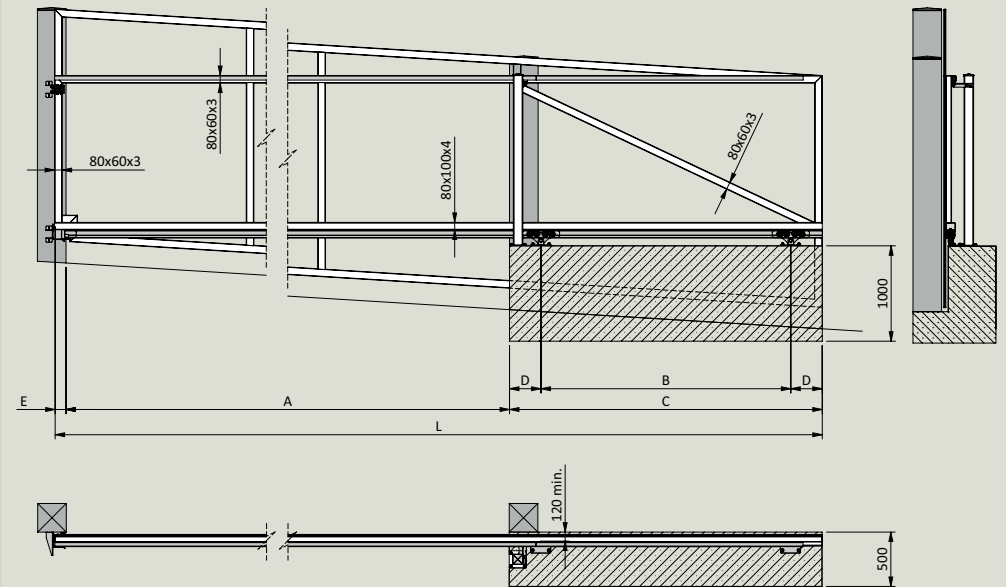
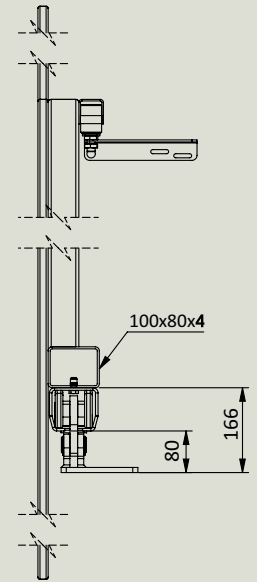

$$L = A + B + (2 \times D) + E$$

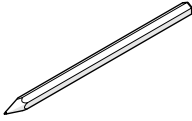
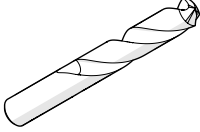
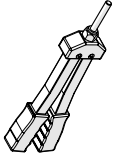
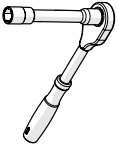

(\*) ONLY SETS

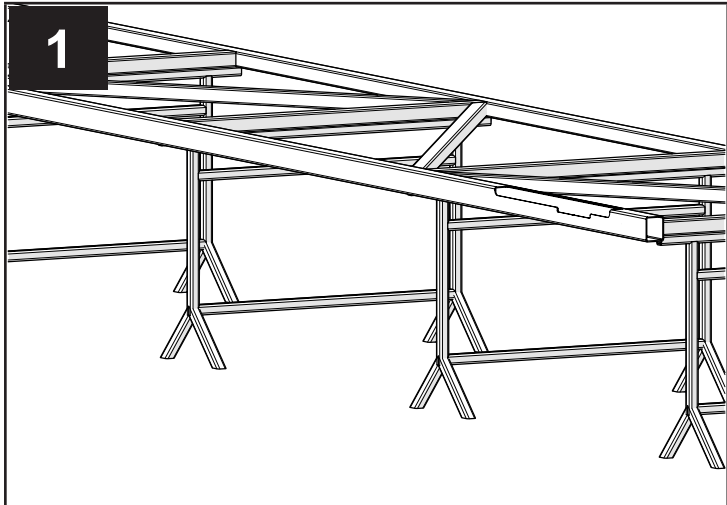
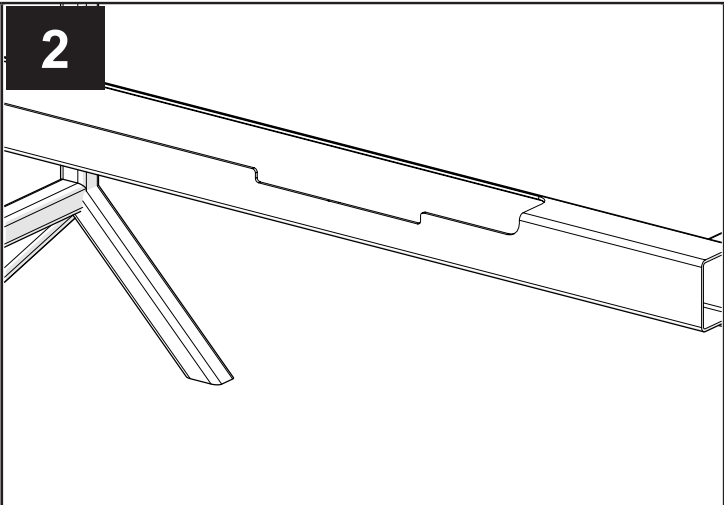
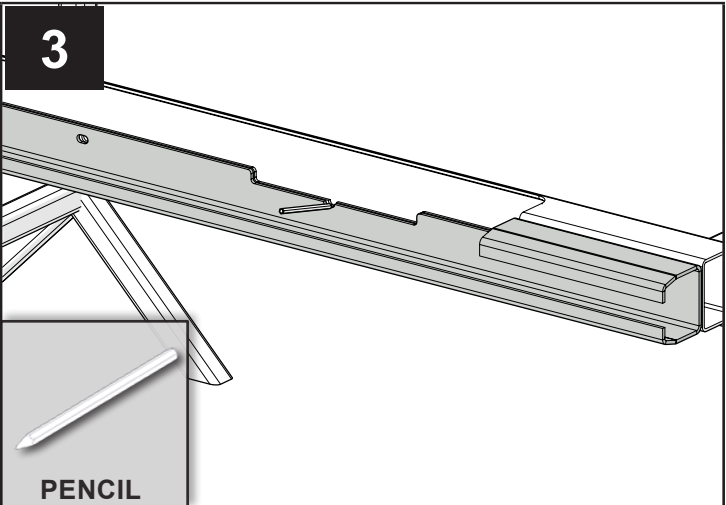
# CAIS MANUAL

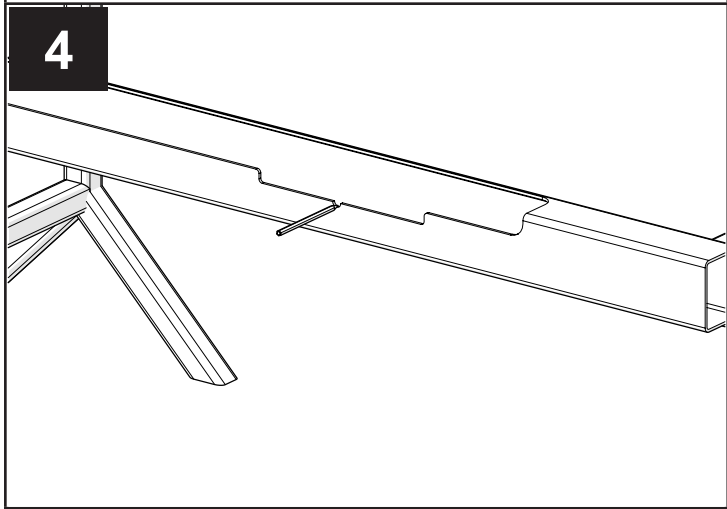
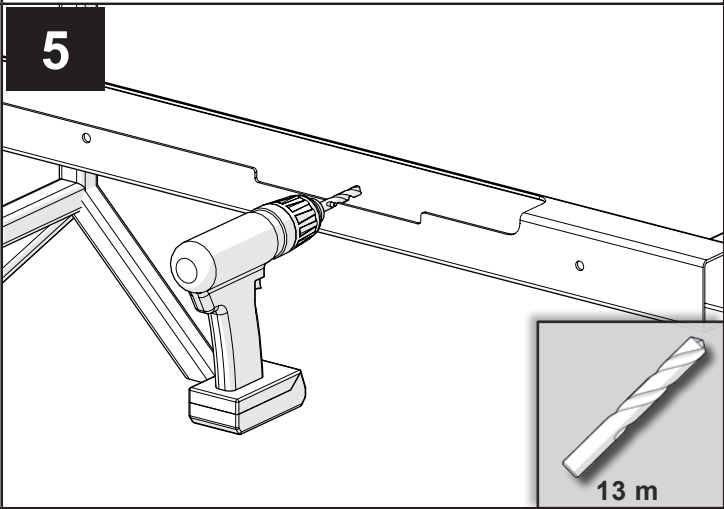
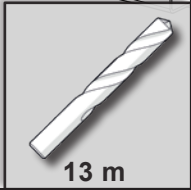
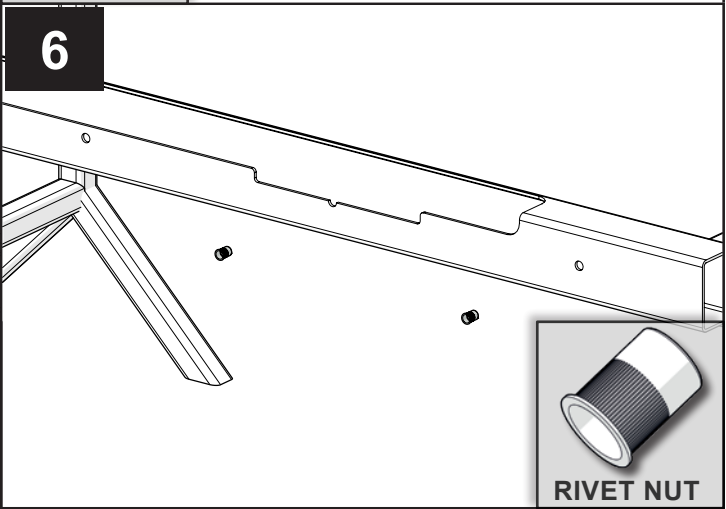
			
Pencil	Drill bit 13mm	Riveting pliers	Ratchet 17 mm

<b>1</b> 	<b>2</b> 	<b>3</b>   PENCIL
<b>4</b> 	<b>5</b>   13 m	<b>6</b>   RIVET NUT

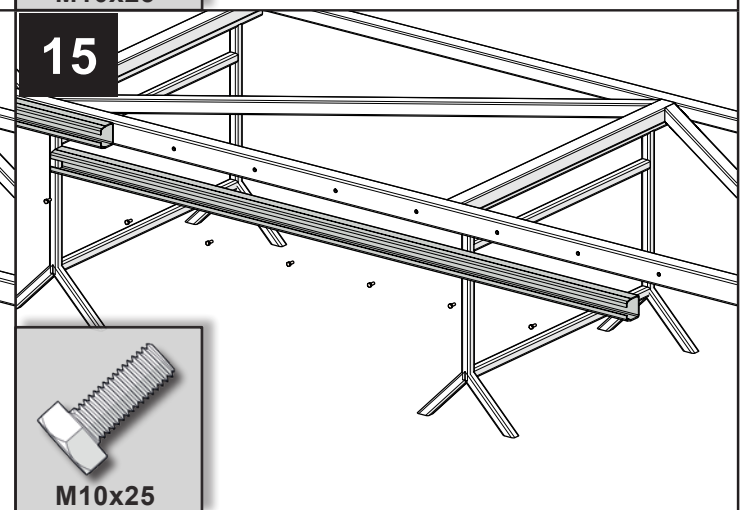
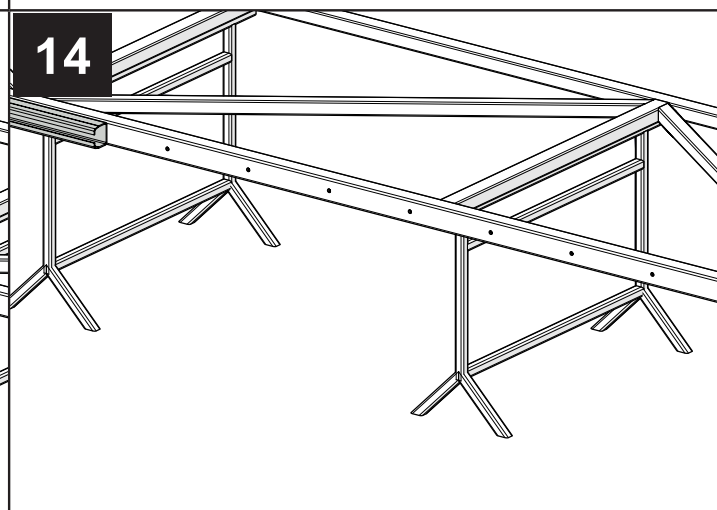
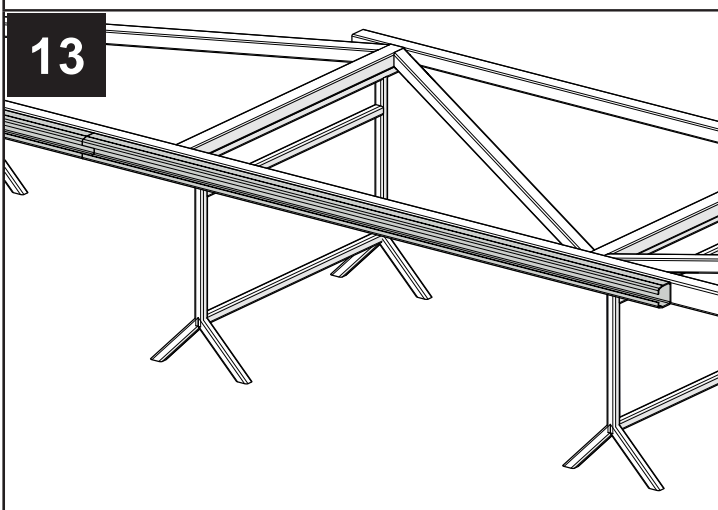
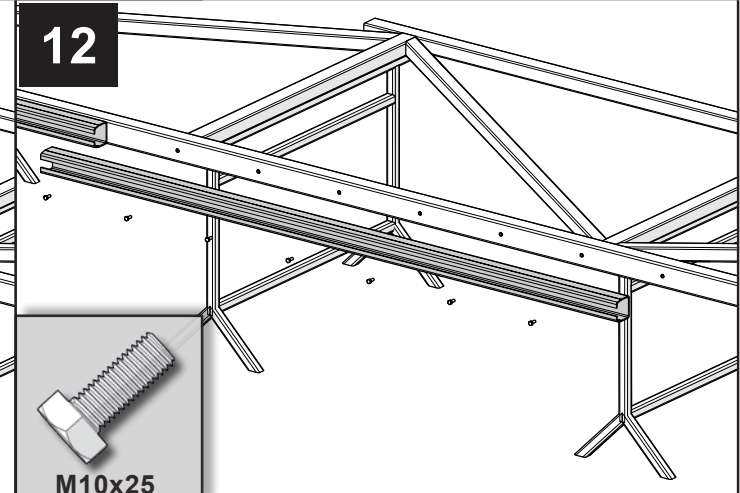
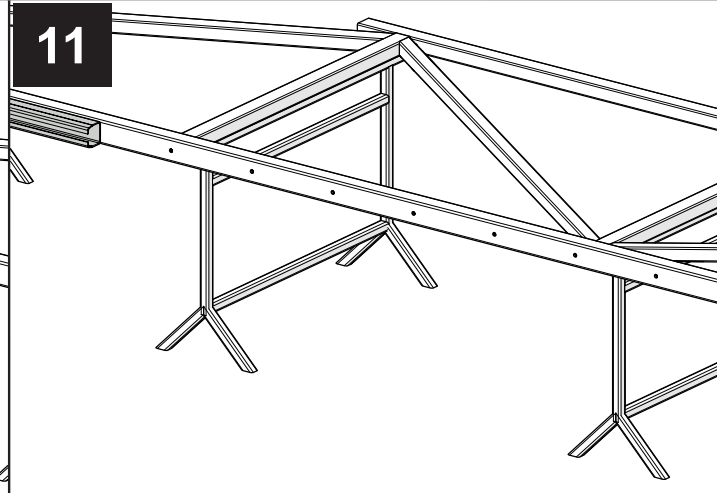
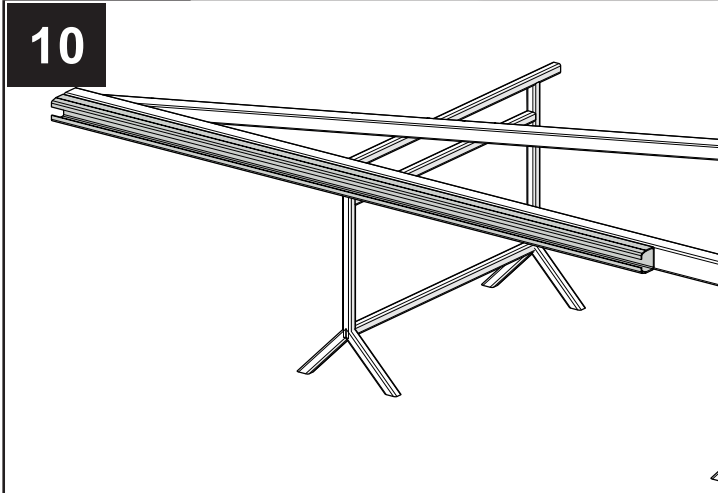
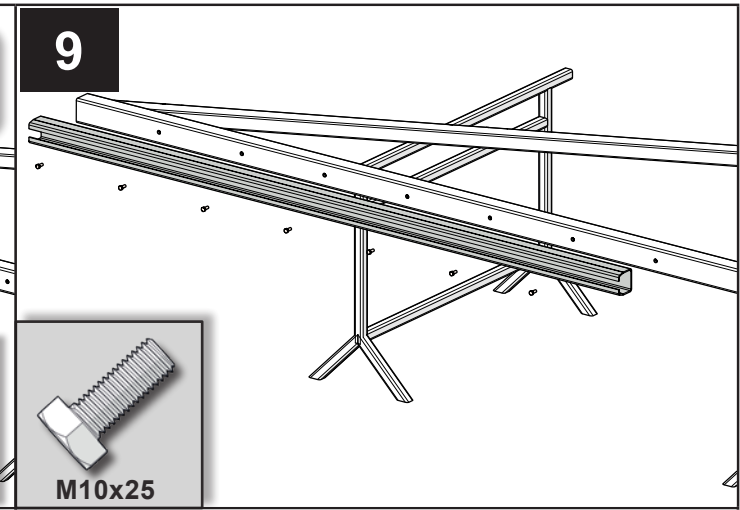
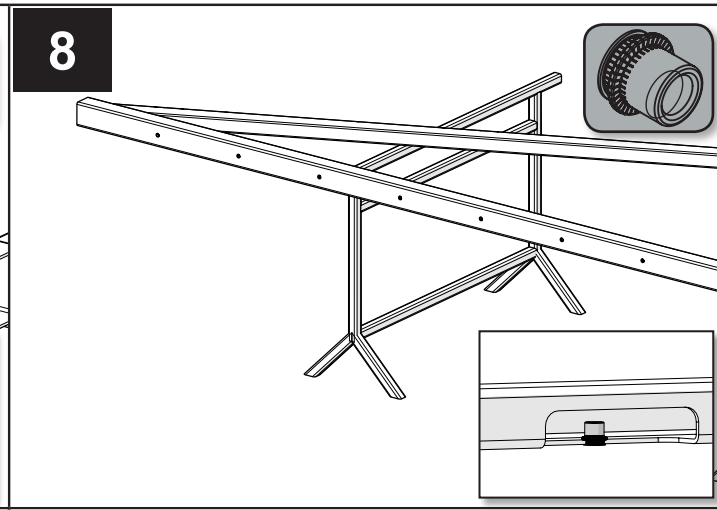
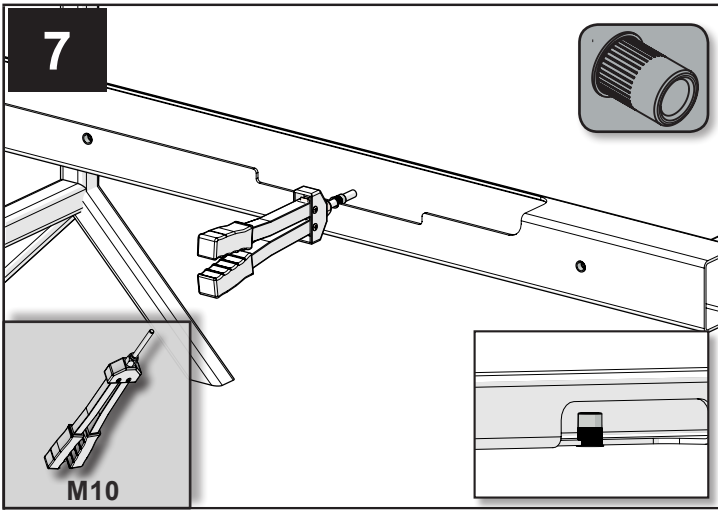

16

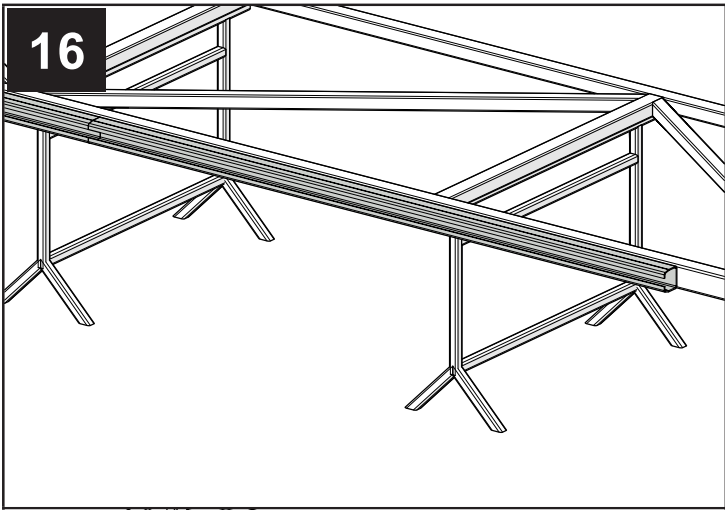

17

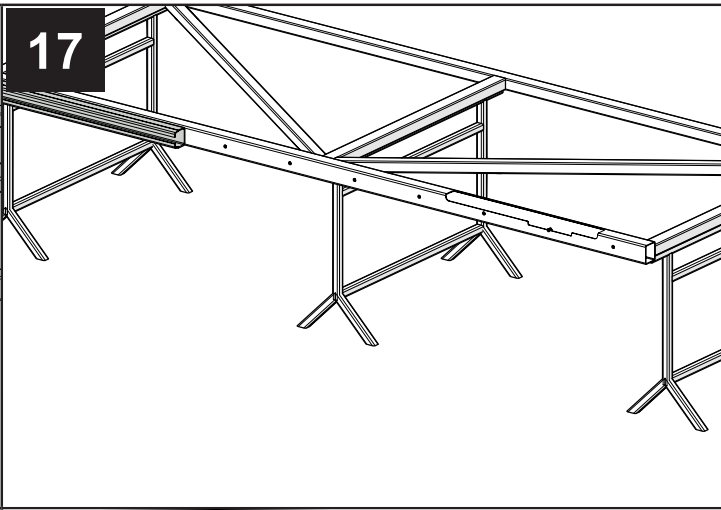

18

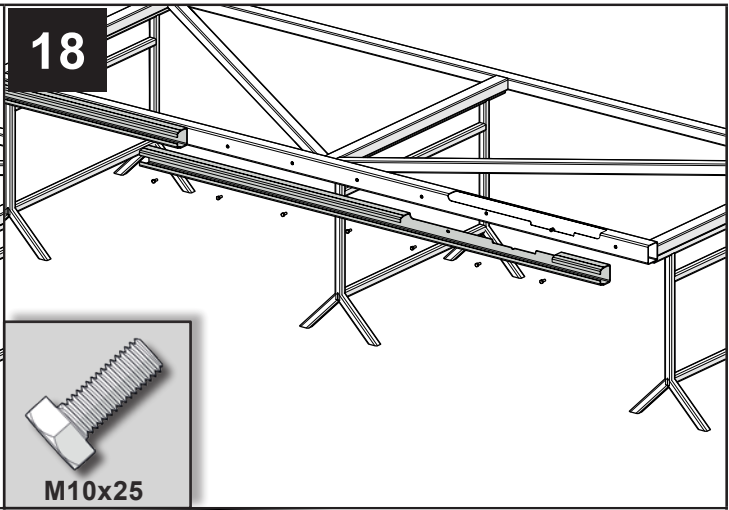

M10x25

19

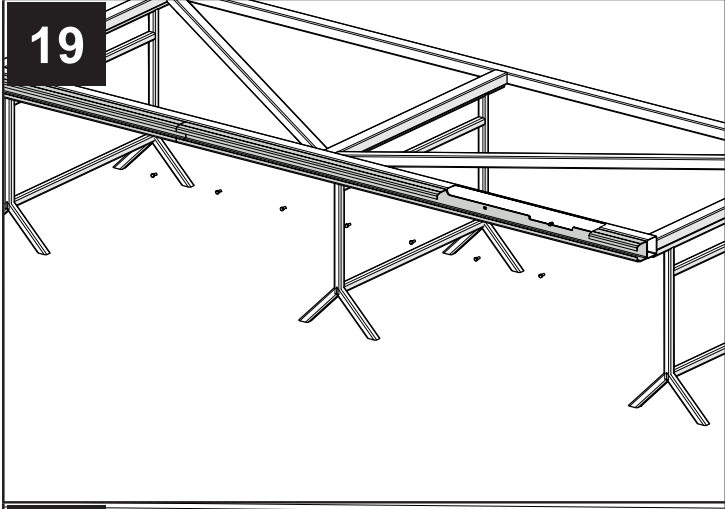

20

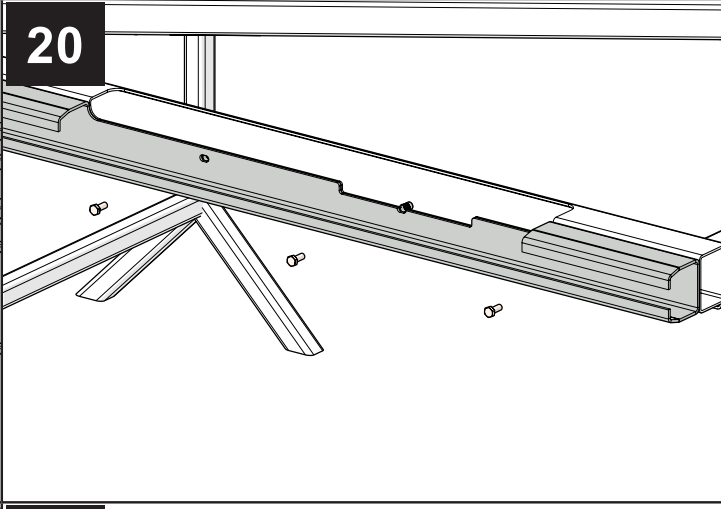

21

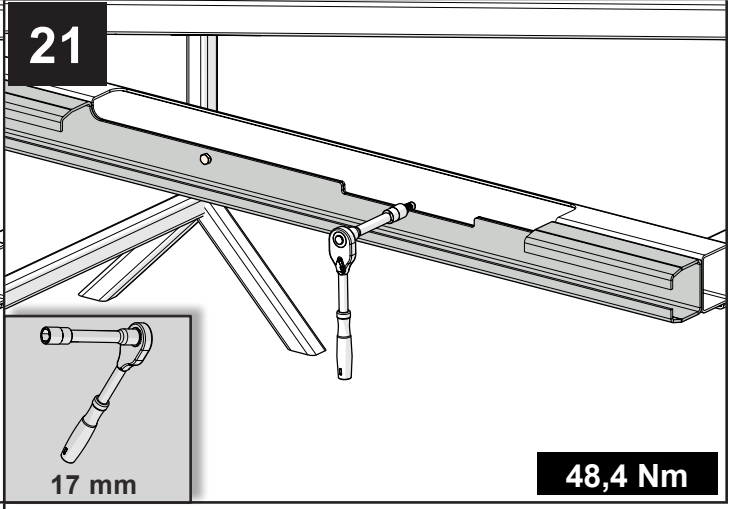

17 mm

48,4 Nm

22

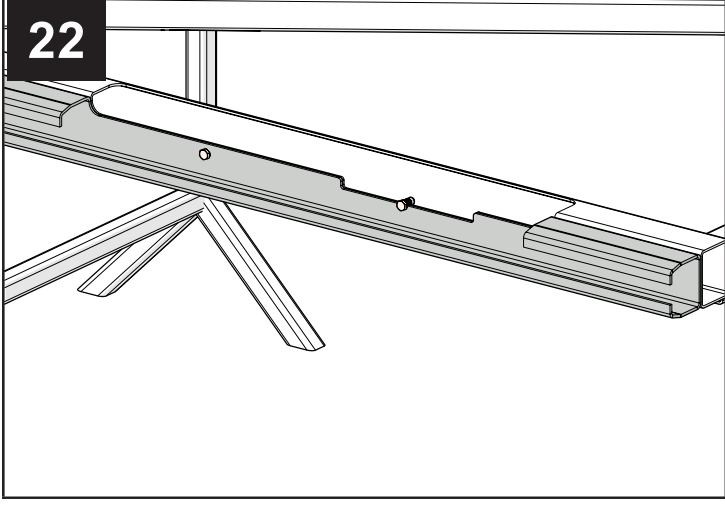

23

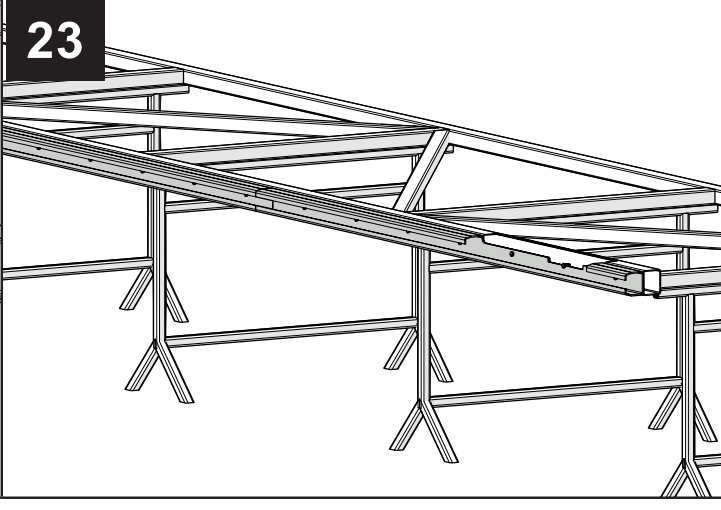

1

SPEED ME; M; MEK

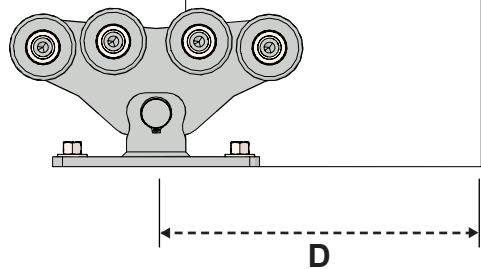

2



3



4

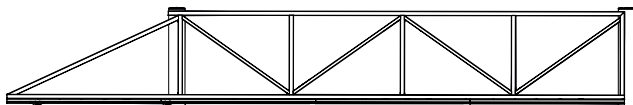

5

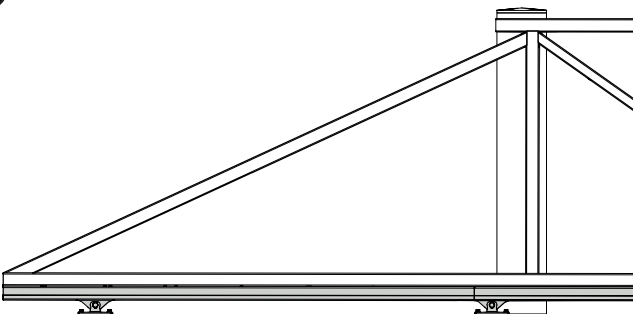

6

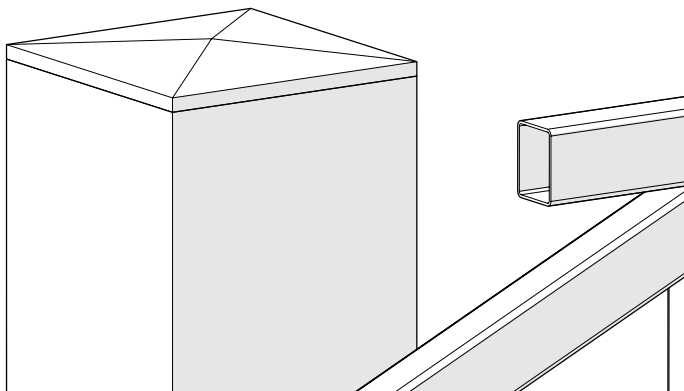

7

FRM 2

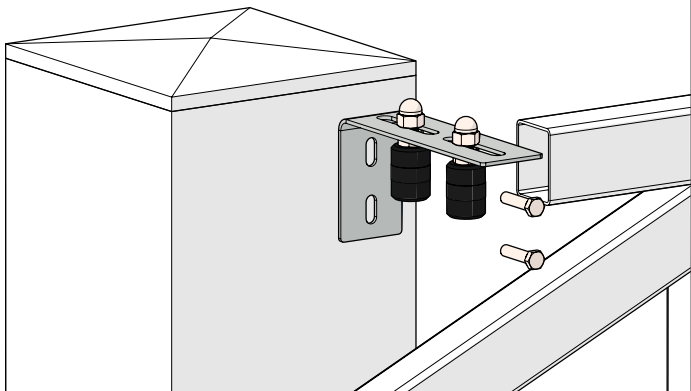

8

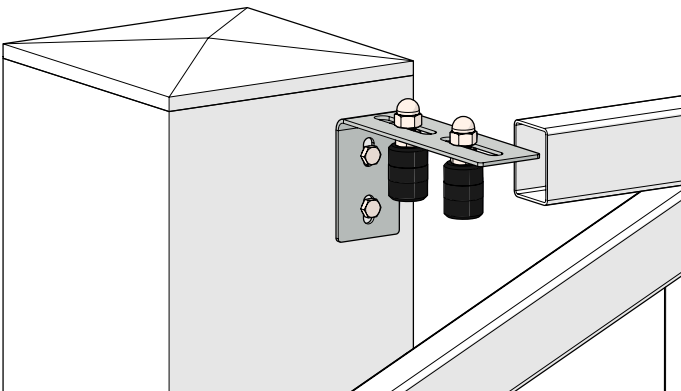

9

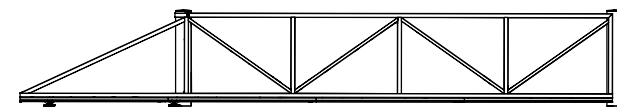

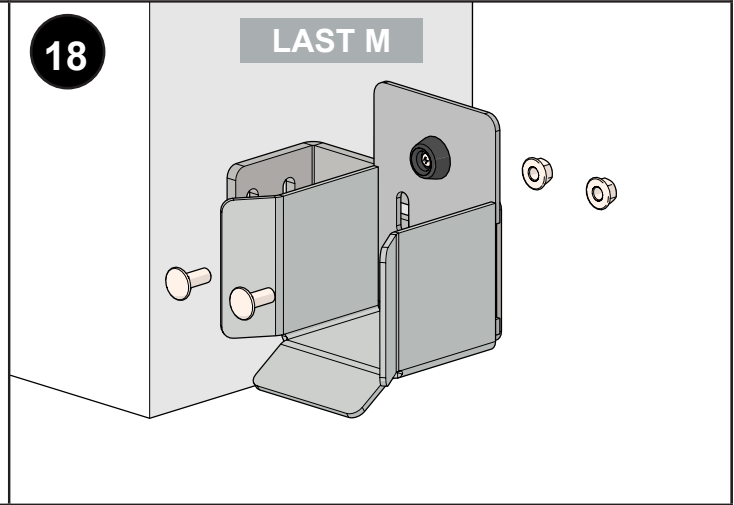
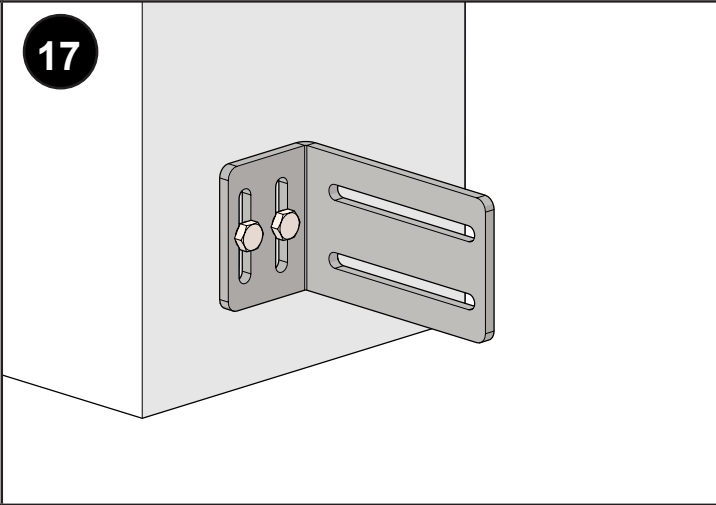
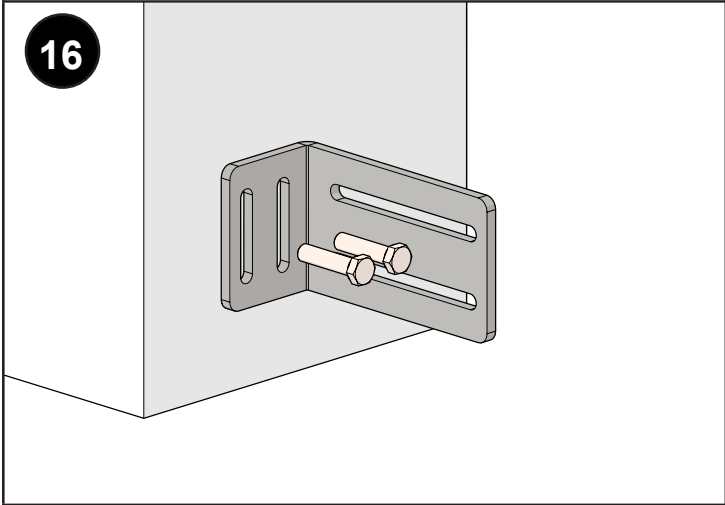
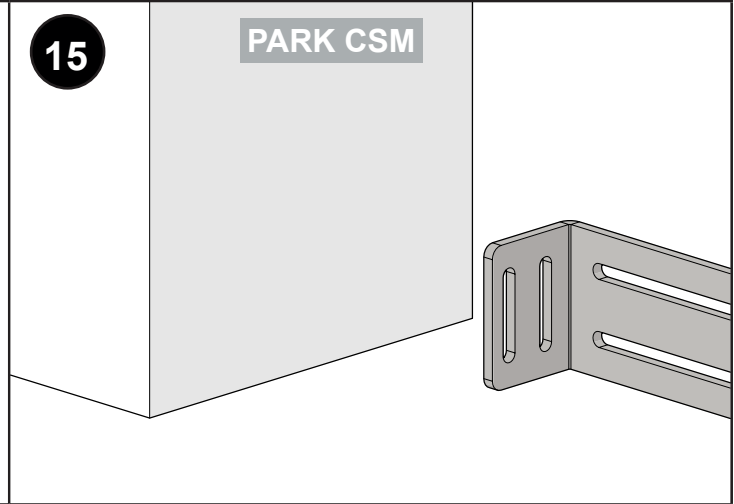
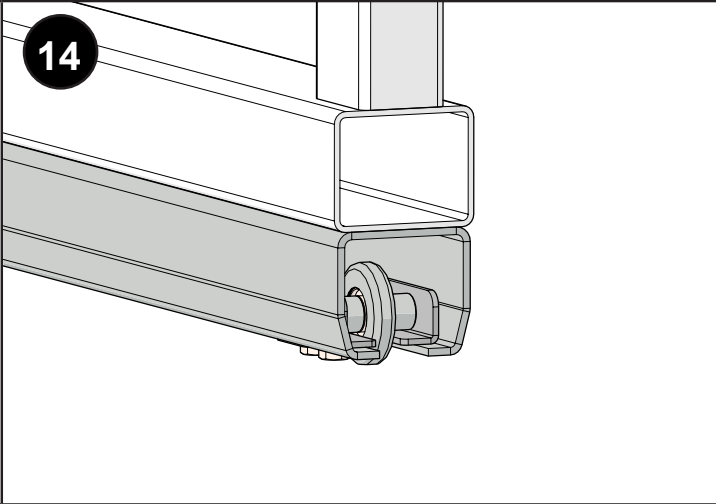
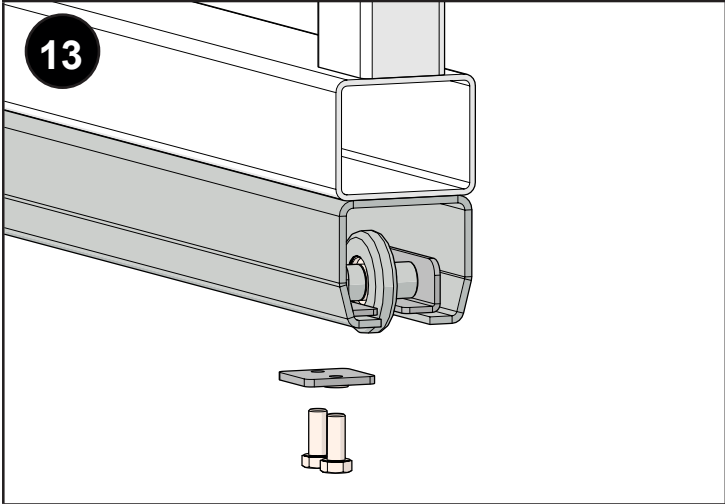
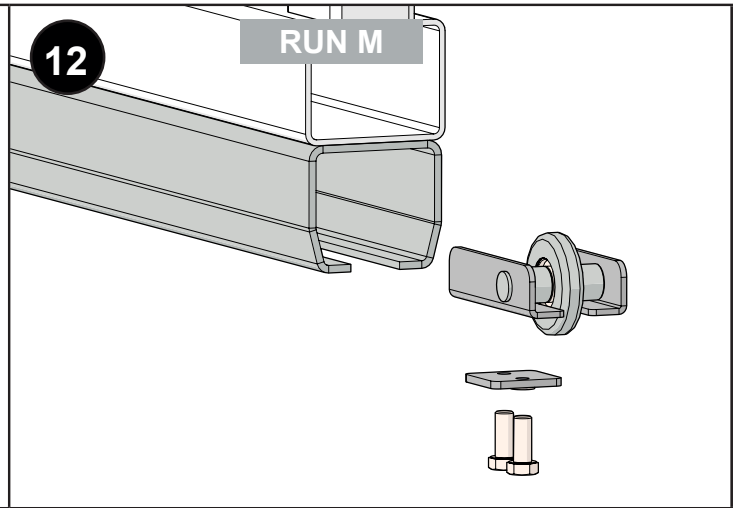
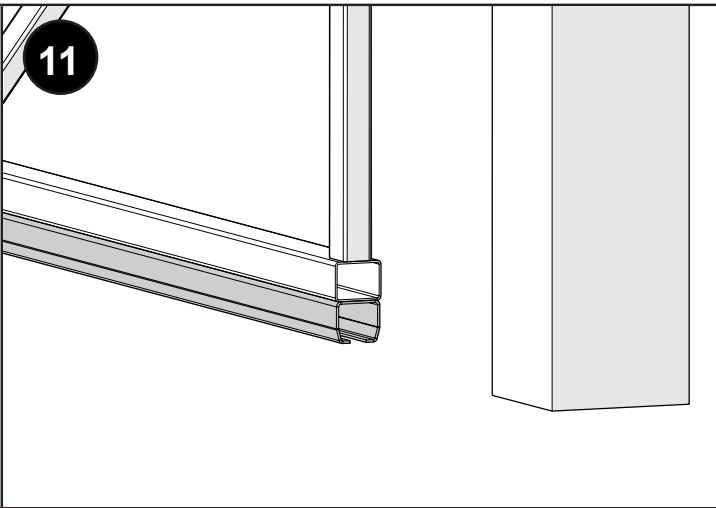
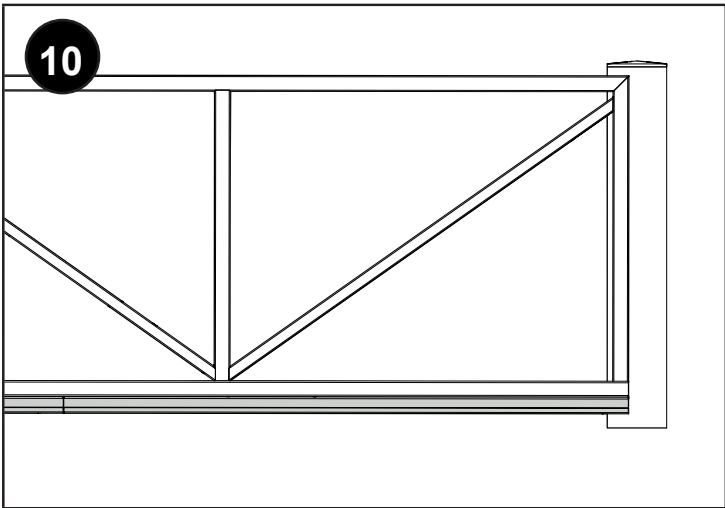

19

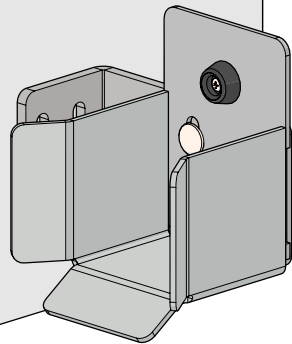

20

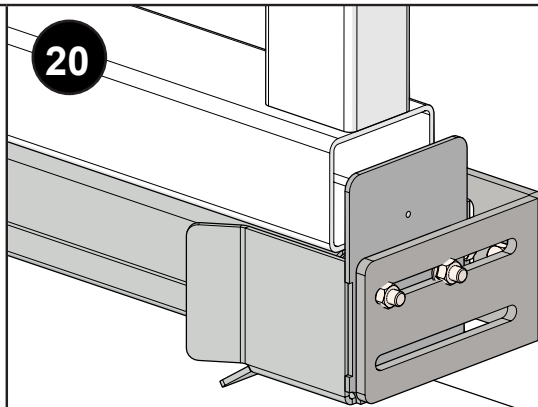

21

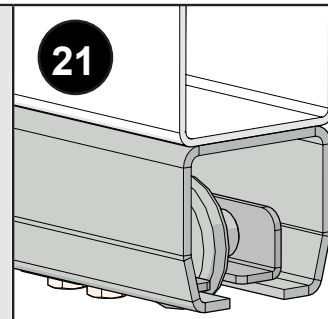

22

PILOT MN

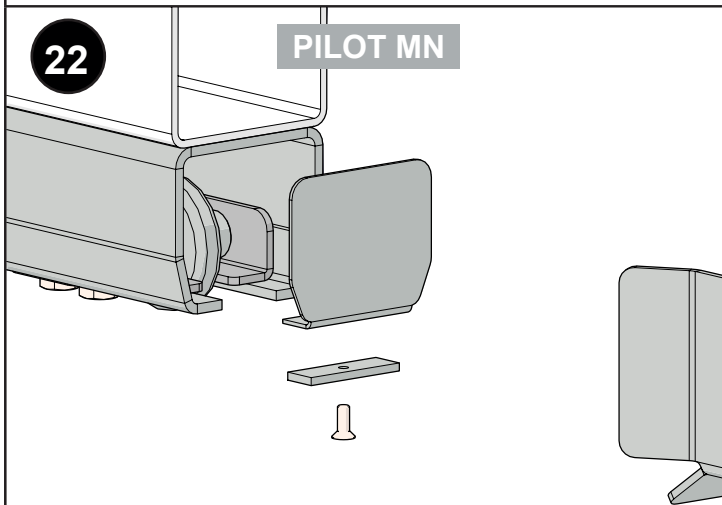

23

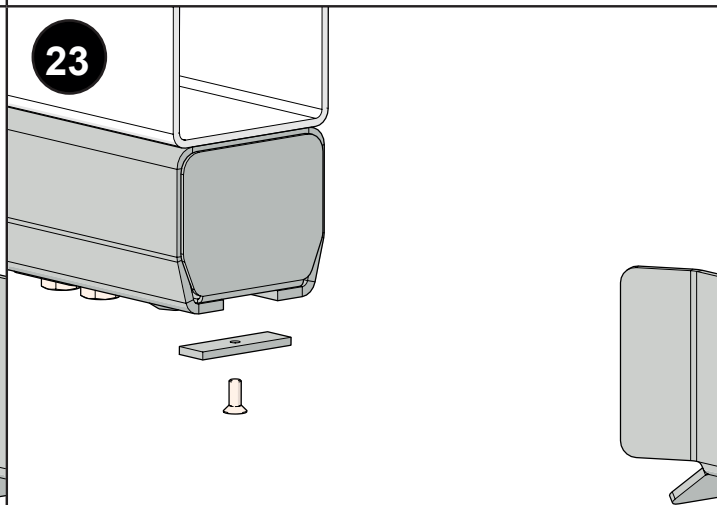

24

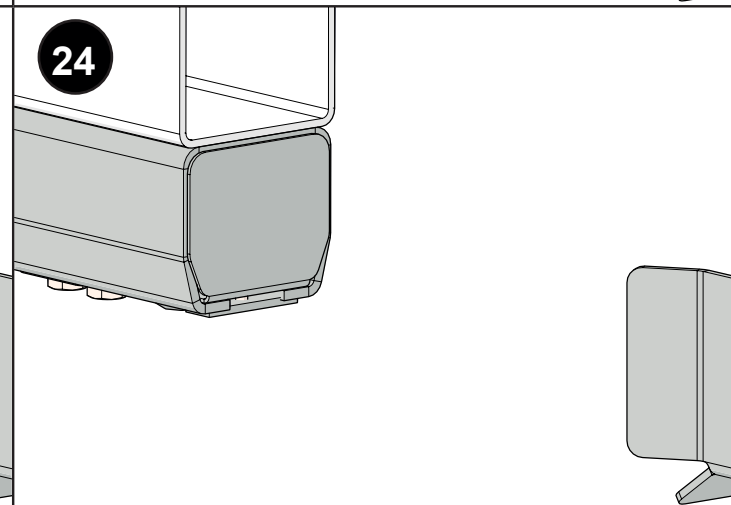

25

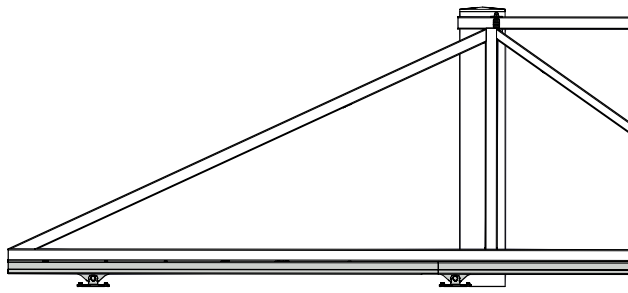

26

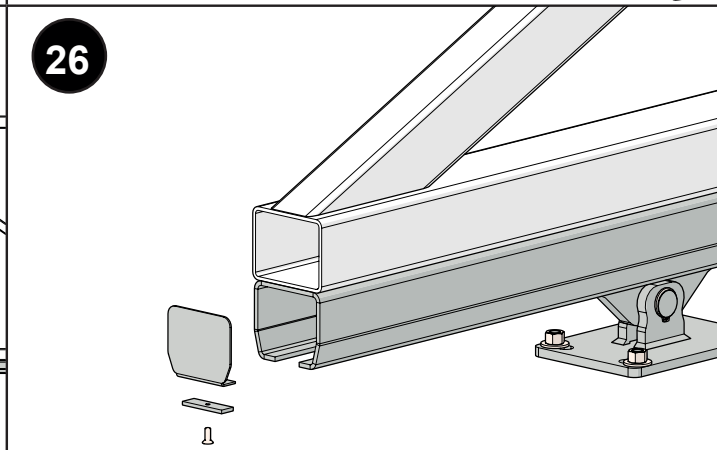

27

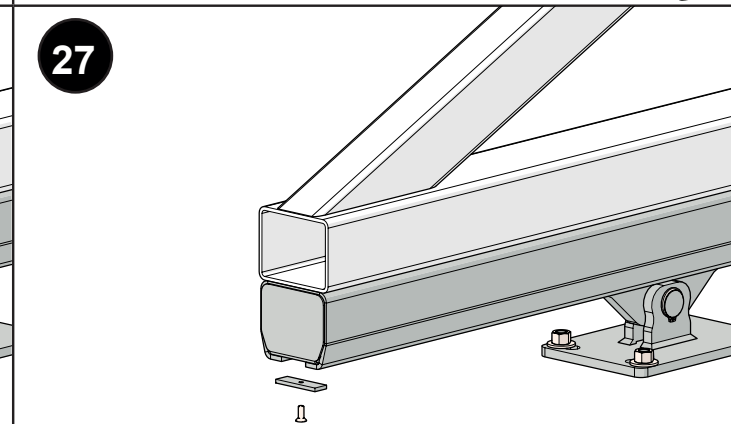



28

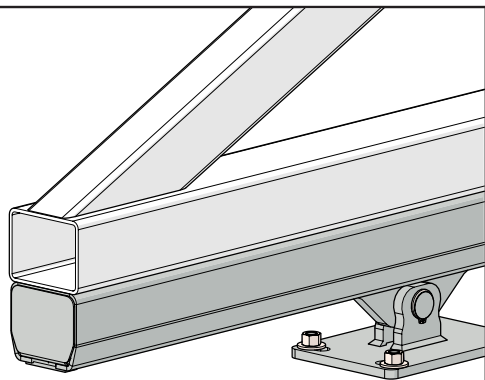

29

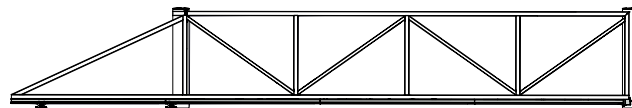



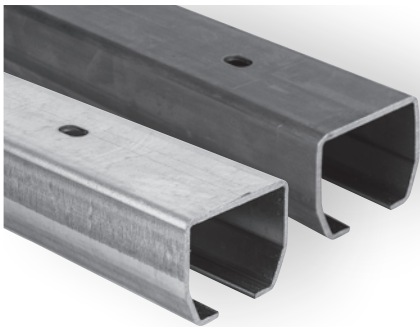

- (GB) „C“ PROFILE GUIDE FOR CANTILEVER GATE
- (D) „C“ PROFIL FÜR FREITRAGENDE SCHIEBETÖRE
- (F) GUIDE À PROFIL EN « C » POUR PORTAIL AUTOPORTANT
- (E) GUÍA CON PERFIL "C" PARA PUERTA VOLADIZA
- (P) GUIA DE PERFIL "C" PARA PORTÃO CANTILEVER
- (I) GUIDA CON PROFILO A "C" PER CANCELLO AUTOPORTANTE
- (DK) "C" PROFILVANGE TIL FRITTBÆRENDE PORT
- (NL) "C" PROFIEL GELEIDER VOOR VRIJDRAGENDE SCHUIFPOOR
- (N) "C"-PROFILSKINNE FOR FRITTBÆRENDE PORTX
- (S) "C" GEJDPROFIL FÖR FRIBÄRANDE GRIND
- (FIN) "C" -PROFILIOHJAIN ULOKEKANNETTEISEEN PORTTIIN
- (PL) SZYNA DO BRAM SAMONOŚNYCH
- (SK) NOSNÝ „C“ PROFIL PRE POSUVNÚ SAMONOSNÚ BRÁNU
- (EE) "C"-PROFILI JUHIK KONSOLVÄRAVA JAOKS
- (LT) „C“ FORMOS PROFILIUOTAS KREIPTUVAS GEMBINIAMS VARTAMS
- (LV) "C" VEIDA PROFILS KONSOLVEIDA VĀRTIEM

- (CZ) SÍNA „C“ PROFIL PRO POSUVNOU SAMONOSNOU BRÁNU
- (RO) GHIDAJ CU PROFIL „C“ PENTRU POARTA AUTOPORTANTĂ ÎN CONSOLĂ
- (HR) VODILICA „C“ PROFILA ZA KLIZNA DVORIŠNA VRATA
- (RUS) НАПРАВЛЯЮЩИЙ РЕЛЬС / ПРОФИЛЬ «С» ДЛЯ ОТКАТНЫХ САМОНЕСУЩИХ ВОРОТ
- (SLO) "C" VODILO ZA SAMONOSNA DRSNA VRATA
- (TR) KONSOL BAHÇE KAPISI İÇİN "C" PROFIL KIZAĞI
- (AR) اللوادة المدعمة "C" دعامة ذليقة جانبية
- (CHN) 悬臂门"C"型导轨
- (MAL) PANDU PROFIL "C" UNTUK PINTU PAGAR JULUR
- (H) C-VEZETŐSÍN TOLÓKAPUHOZ
- (IL) קורה בברזל "C" לשיער קנולו
- (BG) "C"-ОБРАЗНА РЕЛСА ЗА КОНЗОЛНА ВРТА
- (KO) 캔틸레버 게이트용 "C"차형 프로필 가이드
- (SRB) VODICA „C“ PROFILA ZA SAMONOSIVU KAPIJU

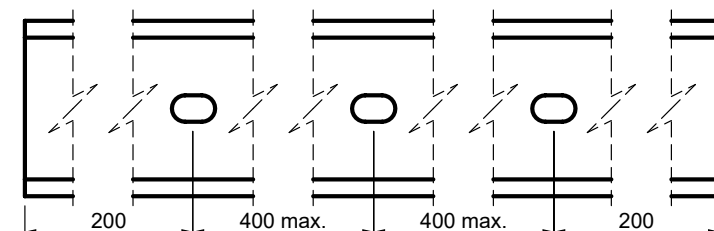
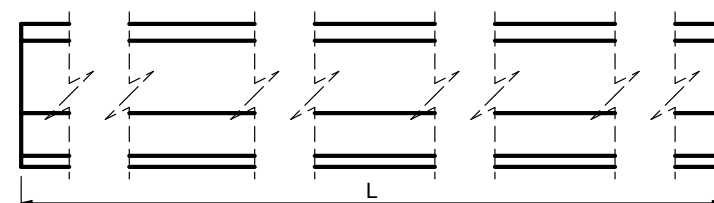
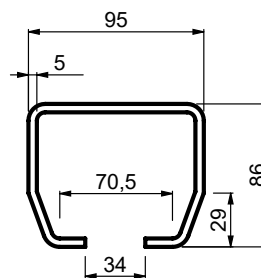
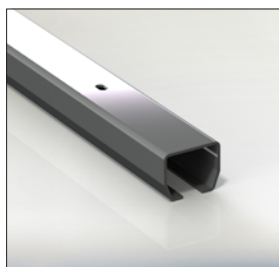
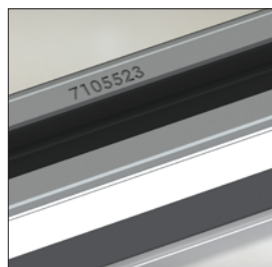
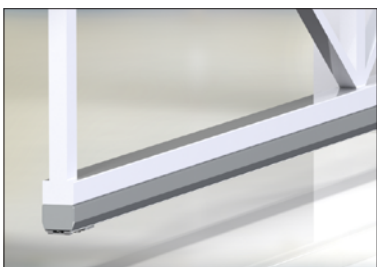

GERMAN STEEL

270 g/m<sup>2</sup> HOT DIPPED GALVANIZED

GALVANIZED INTERNAL EDGES

5,00 mm SPECIAL THICKNESS

24 months 24 MONTHS TESTED & PROVEN

-37°C TESTED & PROVEN

+50°C TESTED & PROVEN

CZ MADE IN CZECH REPUBLIC

BUILD IN FLYING HOLE PUNCH EVERY 400 mm

15 BOLTS 15 RIVET NUTS INCLUDED (\*)

EASY ASSEMBLING

FAST NO WELDING

R&D BRNO UNIVERSITY OF TECHNOLOGY

ARROW STRAIGHT «C» TRACK

18 EIGHTEEN ROLL FORMERS THE MOST IN THE INDUSTRY REMOVE THE INSET «MEMORY» OF STEEL





SLOW ROLLING NO HEAT DURING THE PRODUCTION KEEPING THE MATERIAL WHERE IT IS ROLLED

AVAILABLE CUSTOMISED LENGTHS UNDER SPECIAL TERMS





SERIAL NUMBER CARRIAGE COMPATIBILITY TESTED & PROVEN

Art.	CARRIAGE	SURFACE FINISH	L/1pc	1pc		CODE	
				mm	kg	pcs	kg
STAGE MB 6	SPEED M/ME/MEK	UNGALVANIZED	6000	65,4	12	784,8	1700011
STAGE MB 4	SPEED M/ME/MEK	UNGALVANIZED	4000	43,6	12	523,2	1700213
STAGE MB 3	SPEED M/ME/MEK	UNGALVANIZED	3000	32,7	12	392,4	1700169
STAGE MB 2	SPEED M/ME/MEK	UNGALVANIZED	2000	21,8	12	261,6	1700214
STAGE MB 1	SPEED M/ME/MEK	UNGALVANIZED	1000	10,9	12	130,8	1720026
STAGE MZ 6	SPEED M/ME/MEK	GALVANIZED	6000	65,4	12	784,8	1700012
STAGE MZ 4	SPEED M/ME/MEK	GALVANIZED	4000	43,6	12	523,2	1700215
STAGE MZ 3	SPEED M/ME/MEK	GALVANIZED	3000	32,7	12	392,4	1700170
STAGE MZ 2	SPEED M/ME/MEK	GALVANIZED	2000	21,8	12	261,6	1700216
STAGE MZ 1	SPEED M/ME/MEK	GALVANIZED	1000	10,9	12	130,8	1720036

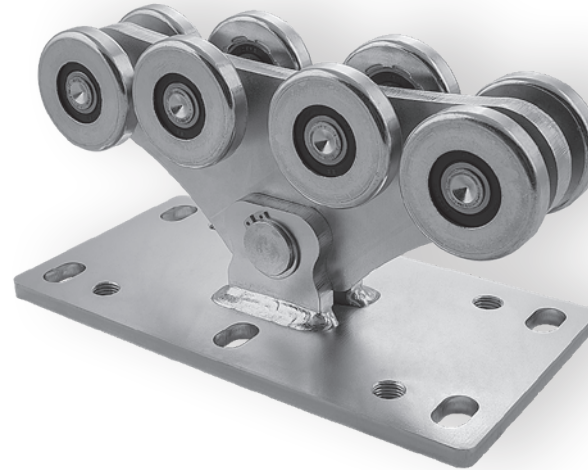

-  C 2  
HQ BEARINGS
-  CARRIAGES CENTER  
HOLES MILLED  
NOT LASERED
-  MULTI RIVETED  
SECTIONS
-  **mono  
block** MONO BLOCK  
EIGHT WHEELED  
CARRIAGE



-  C 2  
HQ BEARINGS
-  CARRIAGES CENTER  
HOLES MILLED  
NOT LASERED
-  MULTI RIVETED  
SECTIONS
-  **mono  
block** MONO BLOCK  
EIGHT WHEELED  
CARRIAGE

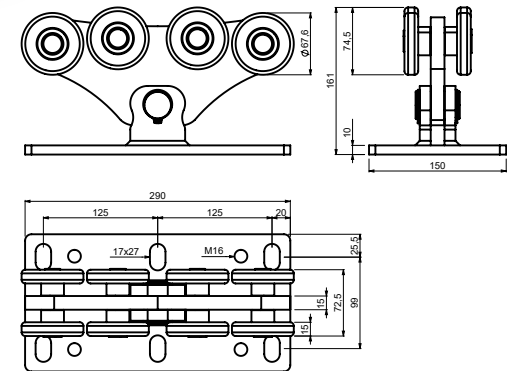
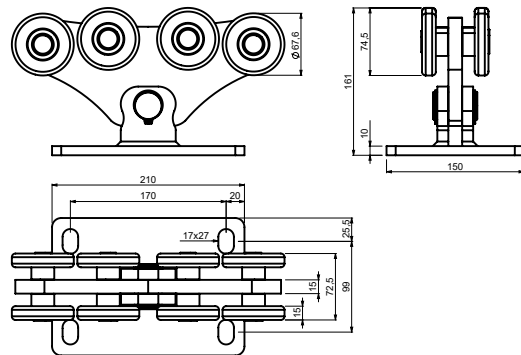

- (GB)** EIGHT WHEELED CARRIAGE FOR CANTILEVER GATE
- (D)** ROLLAPPARAT MIT ACHT ROLLEN FÜR FREITRAGENDE SCHIEBETORE
- (F)** CHARIOT À HUIT ROUES POUR PORTAIL AUTOPORTANT
- (E)** CARRIL DE OCHO RUEDAS PARA PUERTA VOLADIZA
- (P)** CORREDIÇA DE OITO ROLDANAS PARA PORTÃO CANTILEVER
- (I)** CARRELLO A OTTO RUOTE PER CANCELLO AUTOPORTANTE
- (DK)** OTTE TRANSPORTHJUL TIL FRITTBÆRENDE PORT
- (NL)** ACHTVOUDIG WIELENBLOK VOOR VRIJDRAGENDE SCHUIFPOORT
- (N)** ATTEHJULS DRIVSKINNE TIL FRITTBÆRENDE PORT
- (S)** ATTAHJULIG VAGN FÖR FRIBÄRANDE GRIND
- (FIN)** KAHDEKSAN PYÖRÄN ALUSTA ULOKEKANNETTEISEEN PORTTIIN
- (PL)** WÓZEK 8-ROLKOWY DO BRAM SAMONOSNYCH
- (SK)** VOZÍK OSEMKOLIEČKOVÝ PRE POSUVNÚ SAMONOSNÚ BRÁNU
- (EE)** KAHEKSARATTALINE SUPORT KONSOOLVÄRAVA JAOKS
- (LT)** VEŽIMĖLIS GEMBINIAMS VARTAMS SU AŠTUONIAIS RATUKAIS
- (LV)** ASTOŅU RULĻU BLOKS KONSOLVEIDA VĀRTIEM

- (CZ)** VOZÍK OSMIKOLOVÝ PRO POSUVNOU SAMONOSNOU BRÁNU
- (RO)** CĂRUCIOR PE OPT ROTI PENTRU POARTA AUTOPORTANTĂ ÎN CONSOLĂ
- (HR)** NOSAČ S OSAM KOTAČA ZA KLIZNA DVORIŠNA VRATA
- (RUS)** ВОСЬМИКОЛЕСНАЯ РОЛИКОВАЯ ТЕЛЕЖКА ДЛЯ ОТКАТНЫХ САМОНЕСУЩИХ ВОРОТ
- (SLO)** VOZIČEK Z OSMIMI KOLESI ZA SAMONOSNA DRŠNA VRATA
- (TR)** KONSOL BAHÇE KAPISI İÇİN SEKİZ TEKERLEKLİ TAŞIYICI
- (AR)** عربة مزودة بثمانى عجلات للوابت المدعمة
- (CHN)** 悬臂门八轮滑架
- (MAL)** PENYORONG LAPAN RODA UNTUK PINTU PAGAR JULUR
- (H)** NYOLCGÖRGŐS FUTÓKOCSI TOLÓKAPUHOZ
- (IL)** קרנית שמונה גלגלים לשער קובוולי
- (BG)** КОЛИЧКА С ОСЕМ РОЛКИ ЗА КОНЗОЛНА ВРАТА
- (KO)** 8개 휠이 있는 캔틸레버 게이트용 이송대
- (SRB)** NOSAČ SA OSAM TOČKIČA ZA SAMONOSIVU KAPIJU





- (GB)** EIGHT WHEELED CARRIAGE FOR CANTILEVER GATE
- (D)** ROLLAPPARAT MIT ACHT ROLLEN FÜR FREITRAGENDE SCHIEBETORE
- (F)** CHARIOT À HUIT ROUES POUR PORTAIL AUTOPORTANT
- (E)** CARRIL DE OCHO RUEDAS PARA PUERTA VOLADIZA
- (P)** CORREDIÇA DE OITO ROLDANAS PARA PORTÃO CANTILEVER
- (I)** CARRELLO A OTTO RUOTE PER CANCELLO AUTOPORTANTE
- (DK)** OTTE TRANSPORTHJUL TIL FRITTBÆRENDE PORT
- (NL)** ACHTVOUDIG WIELENBLOK VOOR VRIJDRAGENDE SCHUIFPOORT
- (N)** ATTEHJULS DRIVSKINNE TIL FRITTBÆRENDE PORT
- (S)** ATTAHJULIG VAGN FÖR FRIBÄRANDE GRIND
- (FIN)** KAHDEKSAN PYÖRÄN ALUSTA ULOKEKANNETTEISEEN PORTTIIN
- (PL)** WÓZEK 8-ROLKOWY DO BRAM SAMONOSNYCH
- (SK)** VOZÍK OSEMKOLIEČKOVÝ PRE POSUVNÚ SAMONOSNÚ BRÁNU
- (EE)** KAHEKSARATTALINE SUPORT KONSOOLVÄRAVA JAOKS
- (LT)** VEŽIMĖLIS GEMBINIAMS VARTAMS SU AŠTUONIAIS RATUKAIS
- (LV)** ASTOŅU RULĻU BLOKS KONSOLVEIDA VĀRTIEM

- (CZ)** VOZÍK OSMIKOLOVÝ PRO POSUVNOU SAMONOSNOU BRÁNU
- (RO)** CĂRUCIOR PE OPT ROTI PENTRU POARTA AUTOPORTANTĂ ÎN CONSOLĂ
- (HR)** NOSAČ S OSAM KOTAČA ZA KLIZNA DVORIŠNA VRATA
- (RUS)** ВОСЬМИКОЛЕСНАЯ РОЛИКОВАЯ ТЕЛЕЖКА ДЛЯ ОТКАТНЫХ САМОНЕСУЩИХ ВОРОТ
- (SLO)** VOZIČEK Z OSMIMI KOLESI ZA SAMONOSNA DRŠNA VRATA
- (TR)** KONSOL BAHÇE KAPISI İÇİN SEKİZ TEKERLEKLİ TAŞIYICI
- (AR)** عربة مزودة بثمانى عجلات للوابت المدعمة
- (CHN)** 悬臂门八轮滑架
- (MAL)** PENYORONG LAPAN RODA UNTUK PINTU PAGAR JULUR
- (H)** NYOLCGÖRGŐS FUTÓKOCSI TOLÓKAPUHOZ
- (IL)** קרנית שמונה גלגלים לשער קובוולי
- (BG)** КОЛИЧКА С ОСЕМ РОЛКИ ЗА КОНЗОЛНА ВРАТА
- (KO)** 8개 휠이 있는 캔틸레버 게이트용 이송대
- (SRB)** NOSAČ SA OSAM TOČKIČA ZA SAMONOSIVU KAPIJU

Art.	A	GUIDE	1pc	Image		CODE
	max. mm			kg	pcs	
<b>SPEED ME</b>	8000	STAGE MB/MZ	9	2	18	1700009

Art.	A	GUIDE	1pc	Image		CODE
	max. mm			kg	pcs	
<b>SPEED M</b>	8000	STAGE MB/MZ	9,9	2	19,8	1700010



-  SUITABLE FOR INCLINED SURFACE INSTALLATION
-  ASYMMETRIC EIGHT WHEELED CARRIAGE
-  C 2 HQ BEARINGS
- mono block** MONO BLOCK EIGHT WHEELED CARRIAGE
-  CARRIAGES CENTER HOLES MILLED NOT LASERED
-  MULTI RIVITED SECTIONS

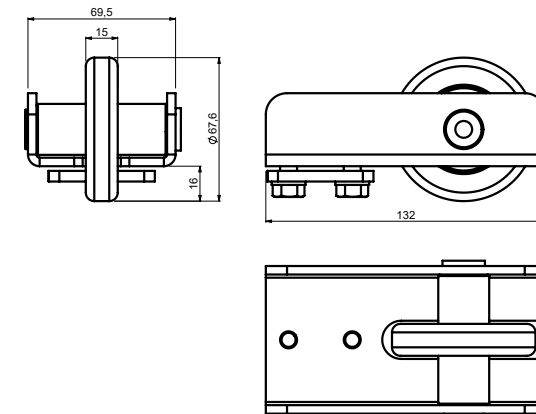
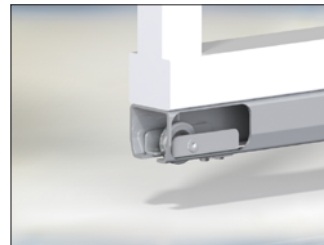
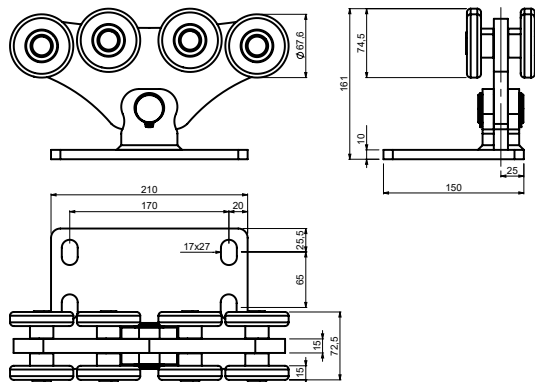
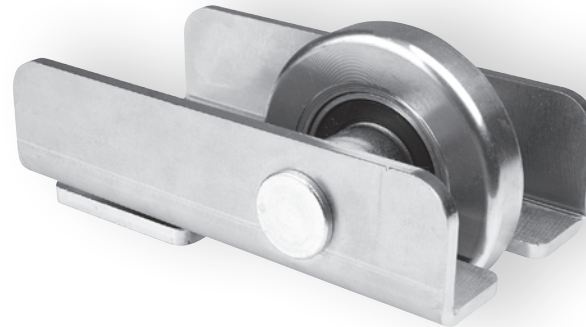

- (GB) EIGHT WHEELED CARRIAGE FOR CANTILEVER GATE
- (D) ROLLAPPARAT MIT ACHT ROLLEN FÜR FREITRAGENDE SCHIEBETORE
- (F) CHARIOT À HUIT ROUES POUR PORTAIL AUTOPORTANT
- (E) CARRIL DE OCHO RUEDAS PARA PUERTA VOLADIZA
- (P) CORREDIÇA DE OITO ROLDANAS PARA PORTÃO CANTILEVER
- (I) CARRELLO A OTTO RUOTE PER CANCELLO AUTOPORTANTE
- (DK) OTTE TRANSPORTHJUL TIL FRITTBÆRENDE PORT
- (NL) ACHTVOUDIG WIELENBLOK VOOR VRIJDRAGENDE SCHUIFFPOOR
- (N) ÅTTEHJULS DRIVSKINNE TIL FRITTBÆRENDE PORT
- (S) ÅTTAHLJULIG VAGN FÖR FRIBÄRANDE GRIND
- (FIN) KAHDEKSAN PYÖRÄN ALUSTA ULOKEKANNETTEISEEN PORTTIIN
- (PL) WÓZEK 8-ROLKOWY DO BRAM SAMONOŚNYCH
- (SK) VOZÍK OSEM KOLIEČKOVÝ PRE POSUVNÚ SAMONOSNÚ BRÁNU
- (EE) KAHESARATTALINE SUPORT KONSOOLVÄRAVA JAOKS
- (LT) VEŽIMĖLIS GEMBINIAMS VARTAMS SU AŠTUONIAMS RATUKAIS
- (LV) ASTOŅU RULĻU BLOKS KONSOLVEIDA VĀRTIEM

- (CZ) VOZÍK OSMIKOLOVÝ PRO POSUVNOU SAMONOSNOU BRÁNU
- (RO) CĂRUCIOR PE OPT ROȚI PENTRU POARTA AUTOPORTANTĂ ÎN CONSOLĂ
- (HR) NOSAČ S OSAM KOTAČA ZA KLIZNA DVORIŠNA VRATA
- (RUS) ВОСЬМИКОЛЕСНАЯ РОЛИКОВАЯ ТЕЛЕЖКА ДЛЯ ОТКАТНЫХ САМОНЕСУЩИХ ВОРОТ
- (SLO) VOZIČEK Z OSMIMI KOLESI ZA SAMONOSNA DRSNA VRATA
- (TR) KONSOL BAŃÇE KAPISI İÇİN SEKİZ TEKERLEKLİ TAŞIYICI
- (AR) عربة مزودة بثمانى عجلات للوابت المدعة
- (CHN) 悬臂门八轮滑架
- (MAL) PENYORONG LAPAN RODA UNTUK PINTU PAGAR JULUR
- (H) NYOLCGÖRGŐS FUTÓKOCSI TOLÓKAPUHOZ
- (IL) קרונית שמנונה לגלים לשער קנדולי
- (BG) КОЛИЧКА С ОСЕМ РОЛКИ ЗА КОНЗОЛНА ВРАТА
- (KO) 8개 휠이 있는 캔틸레버 게이트용 이동대
- (SRB) NOSAČ SA OSAM TOČKIČA ZA SAMONOSIVU KAPIJU

- (GB) GUIDE SUPPORT WHEEL FOR CANTILEVER GATE
- (D) STÜTZRAD FÜR FREITRAGENDE SCHIEBETORE
- (F) ROUE DE SUPPORT DE GUIDE POUR PORTAIL AUTOPORTANT
- (E) RUEDA CON SOPORTE DE GUÍA PARA PUERTA VOLADIZA
- (P) ROLDANA DE SUPORTE GUIA PARA PORTÃO CANTILEVER
- (I) RUOTA DI SOSTEGNO DELLA GUIDA PER CANCELLO AUTOPORTANTE
- (DK) VANGESTØTTEHJUL TIL FRITTBÆRENDE PORT
- (NL) DRAAGWIEL VOOR GELEIDING VRIJDRAGENDE SCHUIFFPOOR
- (N) STYRESKINNE FOR STØTTEHJUL TIL FRITTBÆRENDE PORT
- (S) STÖDHJUL FÖR FRIBÄRANDE GRIND
- (FIN) OHJAIMEN TUKIPYÖRÄ ULOKEKANNETTEISEEN PORTTIIN
- (PL) ROLKA NAJAZDOWA DO BRAM SAMONOŚNYCH
- (SK) NÁBEH S KLDKOU PRE POSUVNÚ SAMONOSNÚ BRÁNU
- (EE) JUHI TUGIRATAS KONSOOLVÄRAVA JAOKS
- (LT) KREIPTUVO ATRAMOS RATUKAS GEMBINIAMS VARTAMS
- (LV) VADOTNES BALSTA RULLĪTIS KONSOLVEIDA VĀRTIEM

- (CZ) NÁBEH S KLDKOU PRO POSUVNOU SAMONOSNOU BRÁNU
- (RO) ROATĂ DE SUSȚINERE GHIDAJ PENTRU POARTA AUTOPORTANTĂ ÎN CONSOLĂ
- (HR) NOSIVI KOTAČ VODILICE ZA KLIZNA DVORIŠNA VRATA
- (RUS) КОНЦЕВОЙ РОЛИК ДЛЯ ОТКАТНЫХ САМОНЕСУЩИХ ВОРОТ
- (SLO) PODPORNO KOLO VODILA ZA SAMONOSNA DRSNA VRATA
- (TR) KONSOL BAŃÇE KAPISI İÇİN KIZAK DESTEK TEKERLEĞİ
- (AR) عجلة دعامة دلييلة للوابت المدعة
- (CHN) 悬臂门导轨支轮
- (MAL) RODA SOKONGAN PANDU UNTUK PINTU PAGAR JULUR
- (H) VEZETŐ, MEGTÁMASZTÓ GÖRGŐ TOLÓKAPUHOZ
- (IL) גלגל תומך לישער קנדולי
- (BG) ПОЛКА ЗА РЕЛСА ЗА КОНЗОЛНА ВРАТА
- (KO) 캔틸레버 게이트용 가이드 지지 휠
- (SRB) NOSEČI TOČKIČ VODICE ZA SAMONOSIVU KAPIJU

Art.	A	GUIDE	1pc			CODE
	max. mm		kg	pcs	kg	
<b>SPEED MEK</b>	8000	STAGE MB/MZ	9	2	18	1700190

Art.	GUIDE	1pc			CODE
		kg	pcs	kg	
<b>RUN M</b>	STAGE MB/MZ	1,11	10	11,1	1700013

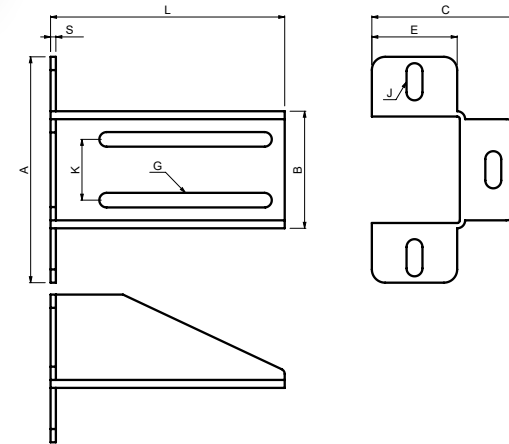
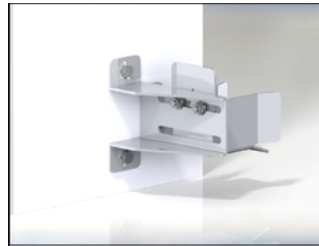
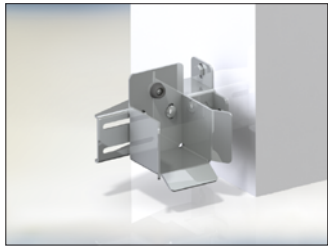
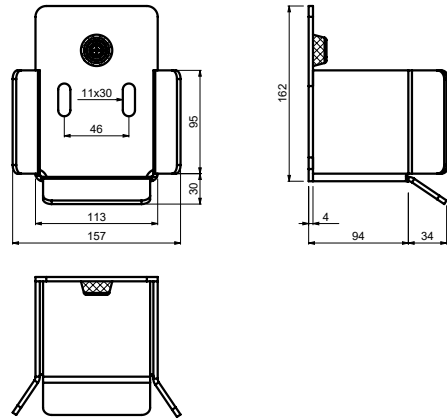

- (GB) END STOP FOR CANTILEVER GATE
- (D) EINLAUFSCHUH FÜR FREITRAGENDE SCHIEBETORE
- (F) BUTÉE POUR PORTAIL AUTOPORTANT
- (E) TOPE FINAL PARA PUERTA VOLADIZA
- (P) BATENTE PARA PORTÃO CANTILEVER
- (I) FERMO DI FINE CORSA PER CANCELLO AUTOPORTANTE
- (DK) ENDESTOP TIL FRITBÆRENDE PORT
- (NL) EINDSTOP VOOR VRIJDRAGENDE SCHUIFPOORT
- (N) ENDESTOPPER FOR FRITTBÆRENDE PORT
- (S) ÄNDSTOPP FÖR FRIBÄRANDE GRIND
- (FIN) PÄÄTYPYSÄYTIN ULOKEKANNETIESEEN PORTTIIN
- (PL) ODBOJNIK DO BRAM SAMONOŚNYCH
- (SK) DOJAZDOVÁ KAPSA SPODNÁ PRE POSUVNÚ SAMONOSNÚ BRÁNU
- (EE) OTSALOPP KONSOLVÄRAVA JAOKS
- (LT) GALINIS RIBOKLIS GEMBINIAMS VARTAMS
- (LV) GALA AIZTURIS KONSOLVEIDA VÄRTIEM

- (CZ) DOJEZDOVÁ KAPSA SPODNÍ PRO POSUVNOU SAMONOSNOU BRÁNU
- (RO) OPRITOR CURSĂ PENTRU POARTA AUTOPORTANTĂ ÎN CONSOLĂ
- (HR) GRANIČNIK ZA KLIZNA DVORIŠNA VRATA
- (RUS) УПРАВЛИТЕЛЬ НИЖНИЙ ДЛЯ ОТКАТНЫХ САМОНЕСУЩИХ ВОРОТ
- (SLO) ZAUSTAVLJALNIK ZA SAMONOSNA DRSNA VRATA
- (TR) KONSOL BAHÇE KAPISI İÇİN UÇ TESPİT PARÇASI
- (AR) المدع الطرفي للبوابة المدعمة
- (CHN) 悬臂门终挡块
- (MAL) PENYENDAL Hujung UNTUK PINTU PAGAR JULUR
- (H) ÜTKÖZŐ TOLÓKAPUHOZ
- (IL) מקבל קצה לשער קונזולי
- (BG) СТОПЕР ЗА КОНЗОЛНА ВРАТА
- (KO) 캔틸레버 게이트용 종단 정지대
- (SRB) GRANIČNIK ZA SAMONOSIVU KAPIJU

- (GB) END STOP BRACKET
- (D) KONSOLE FÜR EINLAUFSCHUH
- (F) ÉTRIER POUR BUTÉE
- (E) SOPORTE DE TOPE FINAL
- (P) SUPORTE DE BATENTE
- (I) STAFFA PER FERMO DI FINE CORSA
- (DK) ENDESTOP BESLAG
- (NL) EINDSTOP BEVESTIGINGSBEUGEL
- (N) STOPPEBRACKET
- (S) ÄNDSTOPP KONSOL
- (FIN) PÄÄTYPYSÄYTIMEN KANNATIN
- (PL) WSPORNIK ODBOJNIKA
- (SK) KONSOLA PRE DOJAZDOVÚ KAPSU
- (EE) OTSALÖPU KLAMBER
- (LT) GALINIO RIBOKLIO GEMBĖ
- (LV) GALA AIZTURA KRONŠTEINS

- (CZ) KONSOLA PRO DOJEZDOVOU KAPSU
- (RO) OPRITOR CURSĂ CONSOLĂ
- (HR) KONSOLA GRANIČNIKA
- (RUS) КРОНШТЕЙН УПРАВЛИТЕЛЯ
- (SLO) OPORNIK ZAUSTAVLJALNIKA
- (TR) UÇ TESPİT PARÇASI DIRSEĞİ
- (AR) سنادة المدع الطرفي
- (CHN) 终挡块支座
- (MAL) PENDAKAP PENYENDAL Hujung
- (H) ÜTKÖZŐ-KERET
- (IL) תופסן לתקבל קצה
- (BG) СКОБА ЗА СТОПЕР
- (KO) 종단 정지대 브래킷
- (SRB) KONSOLA GRANIČNIKA

Art.	GUIDE	1pc	pcs		CODE
		kg	kg	kg	
LAST M	STAGE MB/MZ	1,96	2	3,92	1700014

Art.	L	A	B	C	E	G	J	K	S	END STOP	1pc	pcs		CODE
											kg	kg	kg	
mm														
PARK	175	170	88	95	50	11x132	12x30	46	4	LAST/PADDOCK	1,11	2	2,22	1700006
PARK 240	245	170	88	95	50	11x200	12x30	46	4	LAST/PADDOCK	1,35	2	2,7	1700196



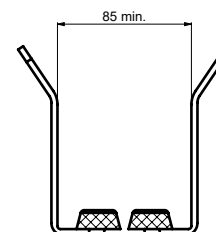
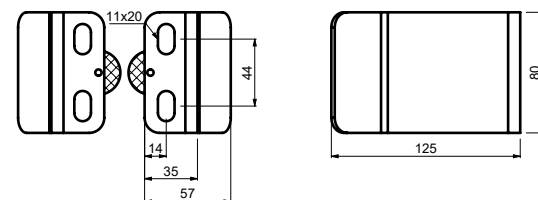
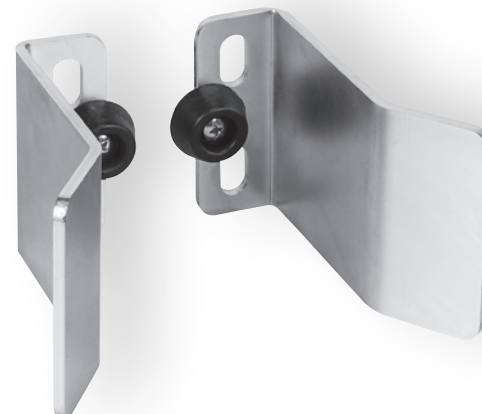
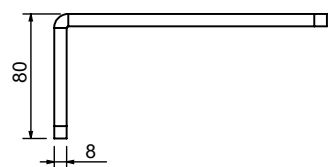
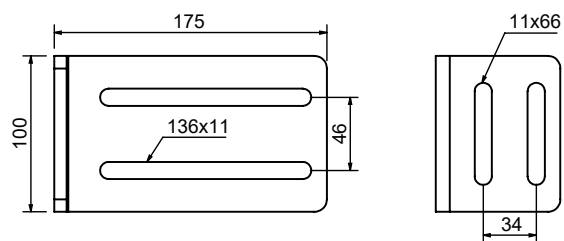
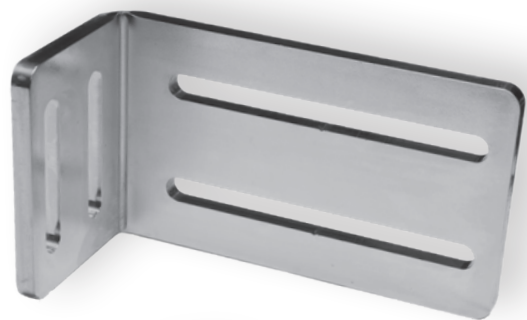



- (GB) END STOP BRACKET
- (D) KONSOLE FÜR EINLAUFSCUHH
- (F) ÉTRIER POUR BUTÉE
- (E) SOPORTE DE TOPE FINAL
- (P) SUPORTE DE BATENTE
- (I) STAFFA PER FERMO DI FINE CORSA
- (DK) ENDESTOP BESLAG
- (NL) EINDSTOP BEVESTIGINGSBEUGEL
- (N) STOPPEBRACKET
- (S) ÄNDSTOPP KONSOL
- (FIN) PÄÄTYPYSÄYTTIMEN KANNATIN
- (PL) WSPORNIK ODBOJNIKA
- (SK) KONZOLA PRE DOJAZDOVÚ KAPSU
- (EE) OTSALÕPU KLAMBER
- (LT) GALINIO RIBOKLIO GEMBĖ
- (LV) GALA AIZTURA KRONŠTEINS

- (CZ) KONZOLA PRO DOJEZDOVOU KAPSU
- (RO) OPRITOR CURSĂ CONSOLĂ
- (HR) KONZOLA GRANIČNIKA
- (RUS) КРОНШТЕЙН УЛАВЛИВАТЕЛЯ
- (SLO) OPORNIK ZAUSTAVLJALNIKA
- (TR) UÇ TESPİT PARÇASI DIRSEĞİ
- (AR) سنادة المانع الطرقي
- (CHN) 终点挡块支座
- (MAL) PENDAKAP PENYENDAL HUJUNG
- (H) ÜTKÖZŐ-KERET
- (IL) תוספת למקבל קצה
- (BG) СКОБА ЗА СТОПЕР
- (KO) 종단 정지대 브래킷
- (SRB) KONZOLA GRANIČNIKA

- (GB) END STOP
- (D) ENDANSCHLAG
- (F) BUTÉE
- (E) TOPE FINAL
- (P) FIM DE CURSO
- (I) ARRESTO TERMINALE
- (DK) ENDESTOP
- (NL) EINDSTOP
- (N) ENDESTOPP
- (S) ÄNDSTOPP
- (FIN) RAJOITIN
- (PL) ZDERZAK KRAŃCOWY
- (SK) DORAZ
- (EE) OTSA LÕPP
- (LT) GALINIS RIBOKLIS
- (LV) GALA AIZTURIS

- (CZ) KONCOVÝ DORAZ
- (RO) OPRITOR FINAL
- (HR) GRANIČNIK
- (RUS) КОНЦЕВОЙ УПОР
- (SLO) KONČNI ELEMENT
- (TR) UÇ TIPASI
- (AR) نقطة التوقف
- (CHN) 限位挡块
- (MAL) ADANG HUJUNG
- (H) VÉGÜTKÖZŐ
- (IL) מקבל מתחום עם מעצור גומי
- (BG) СТОПЕР
- (KO) 종단 정지대
- (SRB) GRANIČNIK

Art.	BRACKET	1pc			CODE
		kg	pcs	kg	
<b>PARK CSM</b>	LAST/PADDOCK	1,36	2	2,72	1700359

Art.	BRACKET	1pc			CODE
		kg	pcs	kg	
<b>PADDOCK SM</b>	PARK/PARK 240/ PARK CSM	0,78	2	1,56	1700194

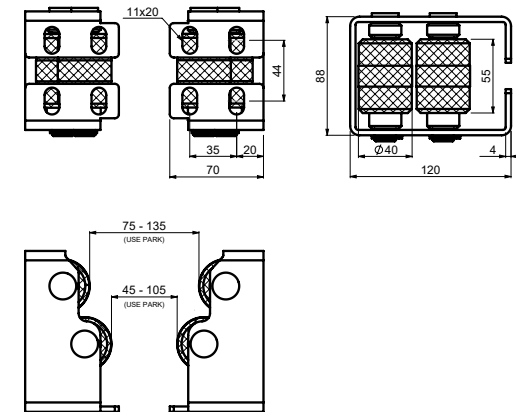
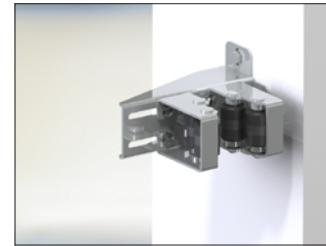
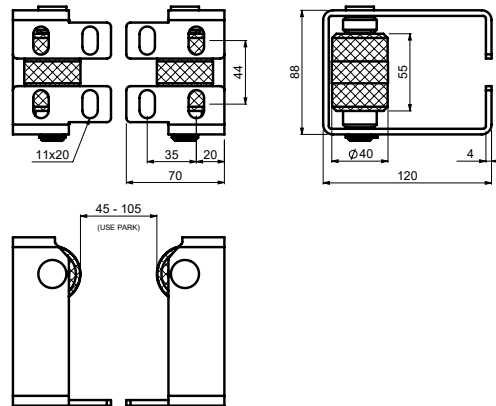
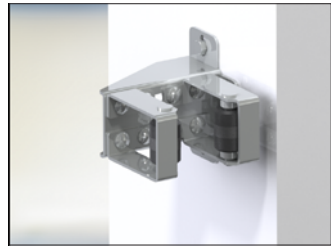
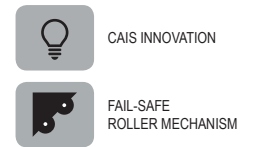
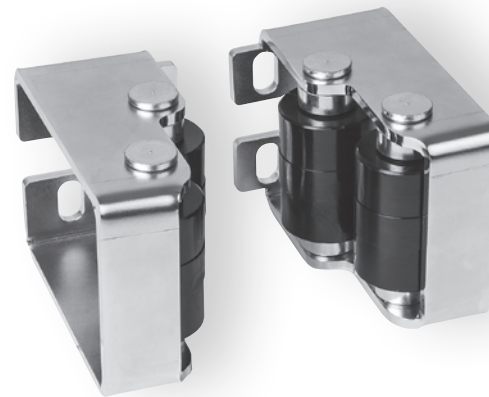
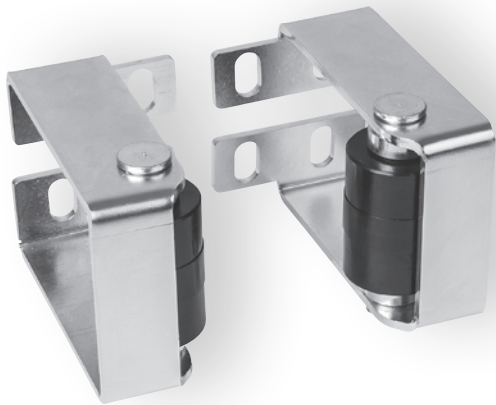

- (GB) END STOP WITH ROLLER
- (D) ENDANSCHLAG MIT ROLLE
- (F) BUTÉE AVEC ROULEAU
- (E) TOPE FINAL CON RODILLO
- (P) FIM DE CURSO COM ROLO
- (I) ARRESTO TERMINALE CON RULLO
- (DK) ENDESTOPP MED VALSE
- (NL) EINDSTOP MET ROLLEN
- (N) ENDESTOPP MED RULLE
- (S) ÄNDSTOPP MED RULLE
- (FIN) RAJOITIN RULLALLA
- (PL) ZDERZAK KRAŃCOWY Z ROLKĄ
- (SK) DORAZ S VALČEKOM
- (EE) OTSALÕPP RULLIKUGA
- (LT) GALINIS RIBOKLIS SU RITINĖLIU
- (LV) GALA AIZTURIS AR RULLĪTI

- (CZ) KONCOVÝ DORAZ S KLADKOU
- (RO) OPRITOR FINAL CU ROLĂ
- (HR) GRANIČNIK S VALJKOM
- (RUS) КОНЦЕВОЙ УПОР С РОЛИКОМ
- (SLO) KONČNI ELEMENT S KOLESCEM
- (TR) MAKARALI UÇ TIPASI
- (AR) نقطة التوقف المزودة بكرة
- (CHN) 带轘子的限位挡块
- (MAL) ADANG Hujung Dengan Penggelek
- (H) VÉGÜTKÖZŐ GÖRGŐVEL
- (IL) מקבל קצה עם גלגלי אוקולון
- (BG) СТОПЕР С РОЛКА
- (KO) 롤러가 있는 종단 정지대
- (SRB) GRANIČNIK SA VALJKOM

- (GB) END STOP WITH ROLLER
- (D) ENDANSCHLAG MIT ROLLE
- (F) BUTÉE AVEC ROULEAU
- (E) TOPE FINAL CON RODILLO
- (P) FIM DE CURSO COM ROLO
- (I) ARRESTO TERMINALE CON RULLO
- (DK) ENDESTOPP MED VALSE
- (NL) EINDSTOP MET ROLLEN
- (N) ENDESTOPP MED RULLE
- (S) ÄNDSTOPP MED RULLE
- (FIN) RAJOITIN RULLALLA
- (PL) ZDERZAK KRAŃCOWY Z ROLKĄ
- (SK) DORAZ S VALČEKOM
- (EE) OTSALÕPP RULLIKUGA
- (LT) GALINIS RIBOKLIS SU RITINĖLIU
- (LV) GALA AIZTURIS AR RULLĪTI

- (CZ) KONCOVÝ DORAZ S KLADKOU
- (RO) OPRITOR FINAL CU ROLĂ
- (HR) GRANIČNIK S VALJKOM
- (RUS) КОНЦЕВОЙ УПОР С РОЛИКОМ
- (SLO) KONČNI ELEMENT S KOLESCEM
- (TR) MAKARALI UÇ TIPASI
- (AR) نقطة التوقف المزودة بكرة
- (CHN) 带轘子的限位挡块
- (MAL) ADANG Hujung Dengan Penggelek
- (H) VÉGÜTKÖZŐ GÖRGŐVEL
- (IL) מקבל קצה עם גלגלי אוקולון
- (BG) СТОПЕР С РОЛКА
- (KO) 롤러가 있는 종단 정지대
- (SRB) GRANIČNIK SA VALJKOM

Art.	BRACKET	1pc			CODE
		kg	pcs	kg	
<b>PADDOCK 2</b>	PARK/PARK 240/ PARK CSM	1,4	2	2,8	1700182

Art.	BRACKET	1pc			CODE
		kg	pc	kg	
<b>PADDOCK 4</b>	PARK/PARK 240/ PARK CSM	2,1	1	2,1	1700191

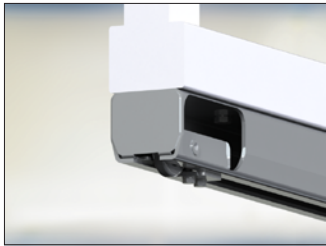
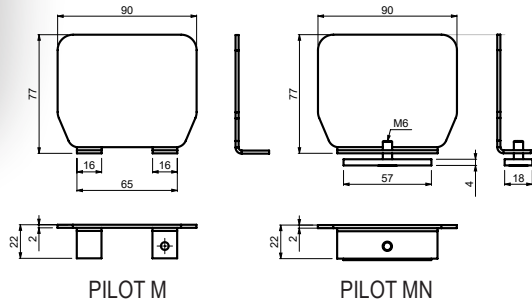

PILOT M

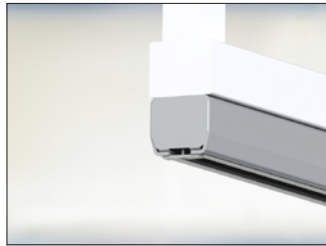

PILOT MN

- GB** GUIDE END CAP WITHOUT SCREW, DEPENDENT ON SUPPORT WHEEL  
GUIDE END CAP WITH SCREW, INDEPENDENT
- D** ABSCHLUSSKAPPE FÜR „C“ PROFIL, ABHÄNGIG VON EINLAUFSCHUH OHNE SCHRAUBE
- F** CACHE EXTRÊMITÉ POUR GUIDE SANS VIS, DÉPENDANT DE LA ROUE DE SUPPORT  
CACHE D'EMBOÛT DE GUIDE AVEC VIS, INDÉPENDANT
- E** TOPE FINAL DE GUÍA SIN TUERCA, DEPENDIENTE DE LA RUEDA DE SOPORTE  
TOPE FINAL DE GUÍA CON TUERCA, INDEPENDIENTE
- P** TAMPÁ FINAL GUIA SEM PARAFUSO, DEPENDENTE DA ROLDANADO SUPORTE  
TAMPÁ FINAL GUIA COM PARAFUSO, INDEPENDENTE
- I** COPERTURA TERMINALE DELLA GUIDA SENZA VITE, DIPENDENTE DALLA RUOTA DI SOSTEGNO. COPERTURA TERMINALE DELLA GUIDA CON VITE, INDEPENDENTE
- DK** VANGEENDEHETTE UDEN SKRUE, AFHÆNGIG AF STØTTEHJUL  
VANGEENDEHETTE MED SKRUE, UAFHÆNGIG
- NL** GELEIDER EINDKAP ZONDER SCHROEF, AFHANKELIJK VAN DRAAGWIEL  
GELEIDER EINDKAP MET SCHROEF, ONAFHANKELIJK
- N** ENDEBESLAG TIL SKINNE UTEN SKRUE, FESTES PÅ STØTTEHJUL  
ENDEBESLAG TIL SKINNE MED SKRUE, UAFHÆNGIG
- S** GEJID SKYDDSKÅPA UTAN SKRUV, BEROENDE PÅ STÖDHJUL  
GEJID SKYDDSKÅPA MED SKRUV, OBEROENDE
- FIN** OHJAIMEN PÄÄN KANSI ILMAN RUUVIA, ERILLINEN TUKIPYÖRÄSSÄ  
OHJAIMEN PÄÄN RUUVILLINEN KANSI, ERILLINEN
- PL** ZAŚLEPKA KOŃCOWA SZYNY BEZ ŚRUBY, ZALEŻNA OD ROLKI NAJAZDOWEJ  
ZAŚLEPKA KOŃCOWA SZYNY ZE ŚRUBĄ, NIEZALEŻNA
- SK** ZÁSLEPKA PRE NOSNÝ „C“ PROFIL, ZÁVISLÁ NA NÁBEHU BEZ SKRUTKY  
A NEZÁVISLÁ SO SKRUTKOU
- EE** „JUHIKU OTSAKORK ILMA KRUVIVA, SÕLTUVALT TUGIRATTAST  
JUHIKU OTSAKORK KRUVIGA, ERALDI“
- LT** „KREIPTUVO GALINIS DANGTELIS BE SRIEGIU, SUSIETAS SU ATRAMINIU RATUKU  
KREIPTUVO GALINIS DANGTELIS SU SRIEGIU, ATSKIRAS“
- LV** „VADOTNES GALA VĀKS BEZ SKRŪVES, ATKARĪGS NO BALSTA RULLIŠA  
VADOTNES GALA VĀKS AR SKRŪVI, NEATKARĪGS“
- CZ** ZÁSLEPKA PRO ŠINU „C“ PROFIL, ZÁVISLÁ NA NÁBĚHU BEZ ŠROUBU A NEZÁVISLÁ SE ŠROUBEM
- RO** ACOPERIRE OPRITOR CURSĂ FĂRĂ FILET, ÎN FUNCȚIE DE ROATA DE SUSȚINERE  
OPRITOR CURSĂ ACOPERIRE GHIDAJ CU FILET, INDEPENDENT
- HR** ČEP VODILICE BEZ VIJKA, OVISNO O NOSIVOM KOTAČU  
ČEP VODILICE S VIJKOM, NEOVISAN
- RUS** ЗАГЛУШКА НАПРАВЛЯЮЩЕГО РЕЛЬСА «С», ЗАВИСИМАЯ ОТ КОНЦЕВОГО РОЛИКА  
БЕЗ ВИНТА И НЕЗАВИСИМАЯ С ВИНТОМ
- SLO** ZAKLJUČNI POKROV VODILA BREZ VIJAKA, ODVISEN OD ZAKLJUČNEGA  
POKROVA VODILA PODPORNEGA KOLESA Z VIJAKOM, NEODVISEN
- TR** VIDASIZ KIZAK UÇ LASTIĞI, DESTEK TEKERLEĞİNE BAĞLI  
VIDALI KIZAK UÇ LASTIĞI, BAĞIMSIZ
- AR** غطاء ناظمي بدون برغي، على حسب عملة الدفعة  
غطاء ناظمي مع برغي، مستقل
- CHN** 非螺釘緊固導軌端蓋，支輪支撐  
螺釘獨立式螺釘緊固端蓋
- MAL** PENUTUP Hujung Pandu Tanpa Skru, Bergantung Pada Roda Sokongan  
Penutup Hujung Pandu Dengan Skru, Bebas
- H** VEZETŐSÍN LEZARÓ-ELEM CSAVAR NÉLKÜL, TÁMASZTÓGÖRGŐTŐL FÜGG  
VEZETŐSÍN LEZARÓ-ELEM CSAVARRAL, FÜGGETLEN
- IL** מסכה לקורה קונדוליית ללא בורג תומאם גלגלי תנוך  
מסכה לקורה קונדוליית עם בורג
- BG** „КРАЙНА КАПАЧКА ЗА РЕЛСА БЕЗ ВИНТ, ЗАВИСИМА ОТ РОЛКАТА ЗА КОНЗОЛНА РЕЛСА  
КРАЙНА КАПАЧКА ЗА РЕЛСА С ВИНТ, САМОСТОЯТЕЛНА“
- KO** 나사가 없는 가이드 종단 캡, 지지용 휠에 의존  
나사가 있는 가이드 종단 캡, 독립식
- SRB** „ČEP VODICE BEZ ZAVRTNJA, ZAVISAN OD NOSEČEG TOČKIČA  
ČEP VODICE SA ZAVRTNJEK, NEZAVISAN“

Art.	GUIDE	1pc		CODE
		kg	pcs	
PILOT M	STAGE MB/MZ	0,11	10	1700015
PILOT MN	STAGE MB/MZ	0,15	10	1700016



CZECH  
R&D



GERMAN  
STEEL



JAPANESE  
ROBOTICS



PRODUCT  
DEVELOPMENT  
PROCESS



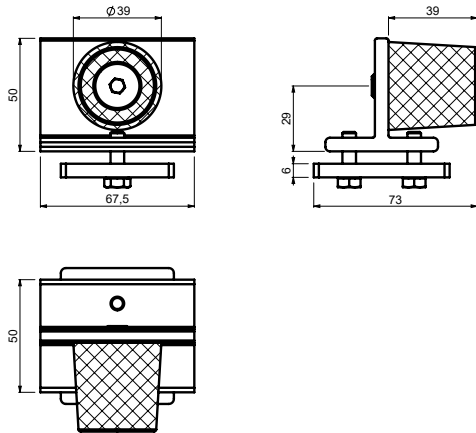
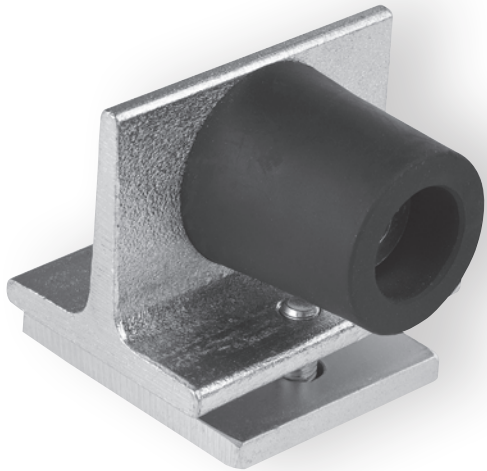

- (GB) INTERNAL GUIDE END STOP
- (D) INNENANSCHLAG FÜR „C“ PROFIL
- (F) BUTÉE INTERNE POUR GUIDE
- (E) TOPE FINAL DE GUÍA INTERNA
- (P) BATENTE GUÍA INTERNA
- (I) FERMO DI FINE CORSA DELLA GUIDA INTERNA
- (DK) INTERN VANGEENDESTOP
- (NL) INTERNE GELEIDER EINDSTOP
- (N) ENDESTOPPER TIL INNVEDIG SKINNE
- (S) INTERNT GEJDÄNDSTOPP
- (FIN) SISÄINEN OHJAIMEN PÄÄN PYSÄYTIN
- (PL) WEWNĘTRZNY ODBOJNIK SZYNY
- (SK) DORAZ VNÚTORŇY PRE NOSNÝ „C“ PROFIL
- (EE) SISEJUHIKU OTSALOPP
- (LT) VIDINIO KREIPTUVO GALINIS RIBOKLIS
- (LV) IEKŠĒJAIS VADOTNES GALA AIZTURIS

- (CZ) DORAZ VNITŘNÍ PRO ŠINU „C“ PROFIL
- (RO) GHIDAJ CAPĂT FINAL INTERN
- (HR) UNUTARNJI GRANIČNIK VODILICE
- (RUS) ВНУТРЕННИЙ ОГРАНИЧИТЕЛЬ НАПРАВЛЯЮЩЕГО РЕЛЬСА «С»
- (SLO) ZAUSTAVLJALNIK NOTRANJEGA VODILA
- (TR) DAHİLİ KIZAK UÇ TESPİT PARÇASI
- (AR) ممانع طرفي نهائي داخلي
- (CHN) 内导轨终点挡块
- (MAL) PENYENDAL Hujung PANDU DALAM
- (H) VEZETŐSÍN BELSŐ ÜTKÖZŐ
- (IL) מעצור פנימי גומי לקוורא
- (BG) БЪТРЕШЕН СТОПЕР ЗА РЕЛСА
- (KO) 내부 가이드 종단 정지대
- (SRB) UNUTRAŠNJI GRANIČNIK VODICE

Art.	GUIDE	1pc		CODE
		kg	pcs	
FINISH M	STAGE MB/MZ	0,48	10	1700017

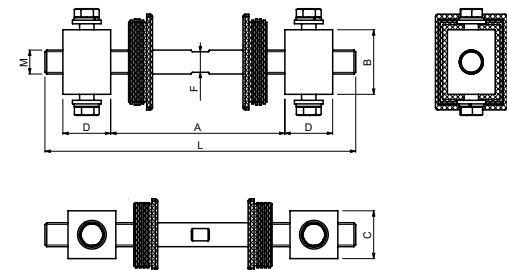
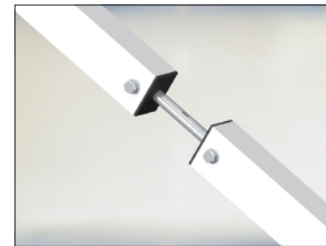
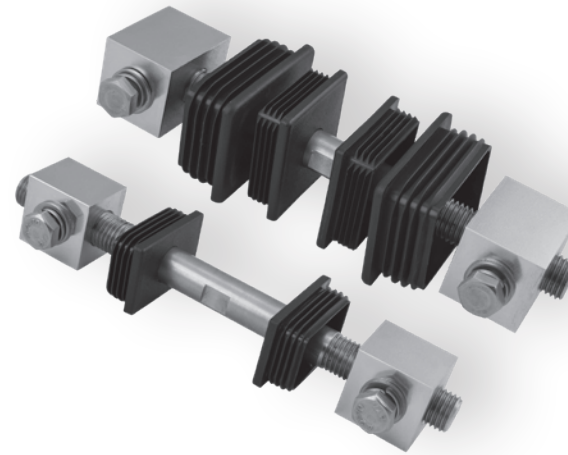

- (GB) ADJUSTABLE TENSION BAR FOR CANTILEVER GATE
- (D) EINSTELLBARE ZUGSTANGE FÜR AUSLEGERTOR
- (F) BARRE DE TENSION RÉGLABLE POUR PORTAIL COULISSANT AUTOPORTANT
- (E) BARRA TENSORA AJUSTABLE PARA PORTÓN EN VOLADIZO
- (P) BARRA DE TENSÃO AJUSTÁVEL PARA PORTÃO CANTILEVER
- (I) TIRANTE DI REGOLAZIONE PER CANCELLO AUTOPORTANTE
- (DK) JUSTERBAR SPÆNDINGSSTANG TIL FRITBÆRENDE PORT
- (NL) VERSTELBARE SPANNINGSBALK VOOR SCHUIFPOORT
- (N) JUSTERBAR STREKKSTANG FOR RULLEPORT
- (S) JUSTERBAR SPÄNNINGSSTÅNG FÖR FRIBÄRANDE GRIND
- (FIN) SÄÄDETTÄVÄ KIRISTYSTANKO ULOKEPORTTIIN
- (PL) REGULOWANA LISTWA NAPINAJĄCA DO BRAMY SAMONOSNEJ
- (SK) NASTAVITELNÁ ŤAŽNÁ TYČ PRE SAMONOSNÉ BRÁNY
- (EE) REGULERITAV PINGUTUSTALA KONSOLVÄRAVA JAOKS
- (LT) REGULIUOJAMA TRAUKĖ GEMBINIAMS VARTAMS
- (LV) REGULĒJAMS STIEPNIS KONSOLVEIDA VĀRTIEM

- (CZ) TENZNÍ TYČ S REGULACÍ PRO POSUVNOU SAMONOSNOU BRÁNU
- (RO) BARĂ DE TENSIUNE REGLABILĂ PENTRU POARTĂ ÎN CONSOLĂ
- (HR) PRILAGODLJIVA STEZNA ŠIPKA ZA NOSIVA VRATA
- (RUS) РЕГУЛИРУЕМЫЙ РАСТЯНУТЫЙ СТЕРЖЕНЬ ДЛЯ САМОНЕСУЩИХ ВОРОТ
- (SLO) NASTAVLJIV NAPENJALNI VZVOD ZA SAMONOSNA DRSNNA VRATA
- (TR) MANIVELA KAPI İÇİN AYARLANABİLİR GERİLİM ÇUBUĞU
- (AR) قضيب الشد القابل للتعديل لوابية الكابول
- (CHN) 可调节悬臂门拉杆
- (MAL) BAR TEGANGAN BOLEH LARAS UNTUK GET JULUR
- (H) ÁLLÍTHATÓ FESZÍTŐRÚD TOLÓKAPUHOZ
- (IL) מוט מתחה מתכוונן לשעור קוונולי
- (BG) РЕГУЛИРУЕМ ОБТЕГАНА ЗА КОНЗОЛНА ВРАТА
- (KO) 캔틸레버 게이트용 조절식 인장대
- (SRB) PODESIVA ZATEZNA ŠIPKA ZA SAMONOSIVU KAPIJU

Art.	L	Amin./max.	B	C	D	M	F	1pc			CODE	
								kg	pcs	kg		
mm												
DIAGON 60	60x40	260	125 - 170	34	40	40	M20	17	1,39	2	2,78	1700237
DIAGON 80	80x60/60x60	260	125 - 180	54	40	40	M20	17	1,95	2	3,9	1700238



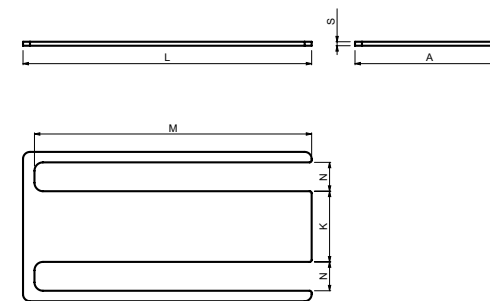
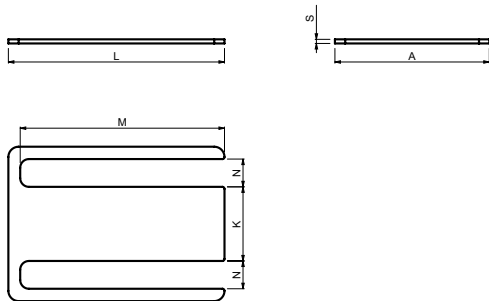
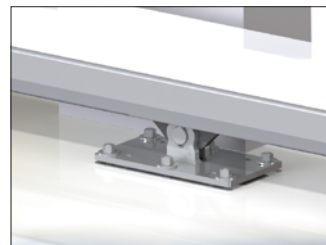
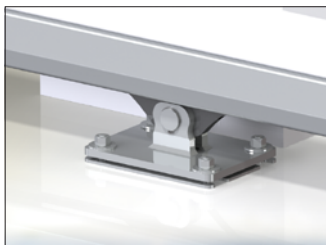
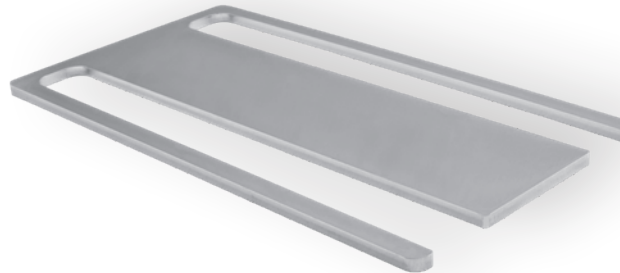
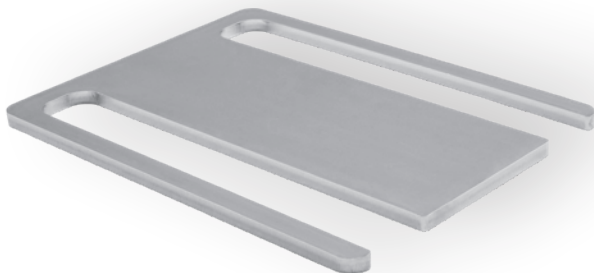



- (GB) WASHER FOR CANTILEVER CARRIAGE
- (D) UNTERLEGSCHIBE FÜR AUSLEGERSCHLITTEN
- (F) RONDELLE POUR CHARIOT CANTILEVER
- (E) TUERCA PARA CARRO EN VOLADIZO
- (P) ARRUELA PARA TRANSPORTE DE CANTILEVER
- (I) RONDELLA PER CARRELLO CANCELLO AUTOPORTANTE
- (DK) SKIVE TIL FRITBÆRENDE PORT
- (NL) RING VOOR SCHUIFWAGEN
- (N) SKIVE FOR RULLEPORTVOGN
- (S) BRICKA FÖR FRIBÄRANDE GRINDVAGN
- (FIN) ALUSLEVY ULOKETELINEESEEN
- (PL) PODKŁADKA DO WÓZKA BRAMY SAMONOŚNEJ
- (SK) PODLOŽKA PRE SAMONOSNÝ NOSNÍK
- (EE) SEIB KONSOOLALUSE JAOKS
- (LT) POVERŽLĖ GEMBINIŲ VARTŲ VEŽIMĖLIUI
- (LV) PĀPLĀKSNE KONSOLES NESOŠAJAM RUĻĻU BLOKAM

- (CZ) PODLOŽKA PRO VOZÍK
- (RO) ȘAIBĂ PENTRU SISTEMUL DE CULISARE ÎN CONSOLĂ
- (HR) PODLOŠKA ZA NOSIVO PODVOZJE
- (RUS) ШАЙБА ДЛЯ РОЛИКОВЫХ ТЕЛЕЖЕК САМОНЕСУЩИХ ВОРОТ
- (SLO) PODLOŽKA ZA VOZIČEK
- (TR) MANİVELA TAŞIYICISI İÇİN RONDELA
- (AR) حلبة ليوابة الكابول
- (CHN) 悬臂架垫片
- (MAL) SESENDAL UNTUK PEMBAWA JULUR
- (H) ALÁTÉT TOLÓKAPU FUTÓKOCSIHOZ
- (IL) חוקה לגלגלים לקרונולי
- (BG) ВЛОЖКА ЗА КОНЗОЛНА КОЛИЧКА
- (KO) 캔틸레버 이동대용 와셔
- (SRB) PODLOŠKA ZA SAMONOSIVU KAPIJU

- (GB) WASHER FOR CANTILEVER CARRIAGE
- (D) UNTERLEGSCHIBE FÜR AUSLEGERSCHLITTEN
- (F) RONDELLE POUR CHARIOT CANTILEVER
- (E) TUERCA PARA CARRO EN VOLADIZO
- (P) ARRUELA PARA TRANSPORTE DE CANTILEVER
- (I) RONDELLA PER CARRELLO CANCELLO AUTOPORTANTE
- (DK) SKIVE TIL FRITBÆRENDE PORT
- (NL) RING VOOR SCHUIFWAGEN
- (N) SKIVE FOR RULLEPORTVOGN
- (S) BRICKA FÖR FRIBÄRANDE GRINDVAGN
- (FIN) ALUSLEVY ULOKETELINEESEEN
- (PL) PODKŁADKA DO WÓZKA BRAMY SAMONOŚNEJ
- (SK) PODLOŽKA PRE SAMONOSNÝ NOSNÍK
- (EE) SEIB KONSOOLALUSE JAOKS
- (LT) POVERŽLĖ GEMBINIŲ VARTŲ VEŽIMĖLIUI
- (LV) PĀPLĀKSNE KONSOLES NESOŠAJAM RUĻĻU BLOKAM

- (CZ) PODLOŽKA PRO VOZÍK
- (RO) ȘAIBĂ PENTRU SISTEMUL DE CULISARE ÎN CONSOLĂ
- (HR) PODLOŠKA ZA NOSIVO PODVOZJE
- (RUS) ШАЙБА ДЛЯ РОЛИКОВЫХ ТЕЛЕЖЕК САМОНЕСУЩИХ ВОРОТ
- (SLO) PODLOŽKA ZA VOZIČEK
- (TR) MANİVELA TAŞIYICISI İÇİN RONDELA
- (AR) حلبة ليوابة الكابول
- (CHN) 悬臂架垫片
- (MAL) SESENDAL UNTUK PEMBAWA JULUR
- (H) ALÁTÉT TOLÓKAPU FUTÓKOCSIHOZ
- (IL) חוקה לגלגלים לקרונולי
- (BG) ВЛОЖКА ЗА КОНЗОЛНА КОЛИЧКА
- (KO) 캔틸레버 이동대용 와셔
- (SRB) PODLOŠKA ZA SAMONOSIVU KAPIJU

Art.	L	A	K	M	N	S	CARRIAGE	1pc			CODE	
									kg	pcs		kg
	mm								kg	pcs	kg	
<b>DESK ME 2</b>	210	150	72	199	27	2	SPEED ME	0,32	4	1,28	1700323	
<b>DESK ME 4</b>	210	150	72	199	27	4	SPEED ME	0,64	4	2,56	1700324	
<b>DESK ME 6</b>	210	150	72	199	27	6	SPEED ME	0,96	4	3,84	1700325	

Art.	L	A	K	M	N	S	CARRIAGE	1pc			CODE	
									kg	pcs		kg
	mm								kg	pcs	kg	
<b>DESK M 2</b>	290	150	72	279	27	2	SPEED M	0,42	4	1,68	1700326	
<b>DESK M 4</b>	290	150	72	279	27	4	SPEED M	0,84	4	3,36	1700327	
<b>DESK M 6</b>	290	150	72	279	27	6	SPEED M	1,26	4	5,04	1700328	

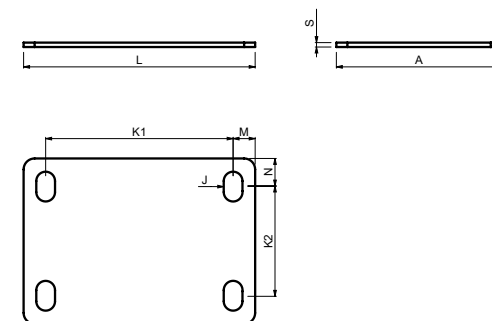
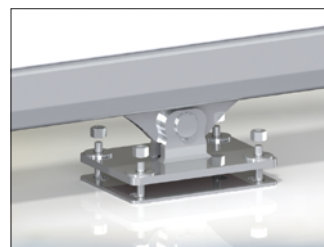
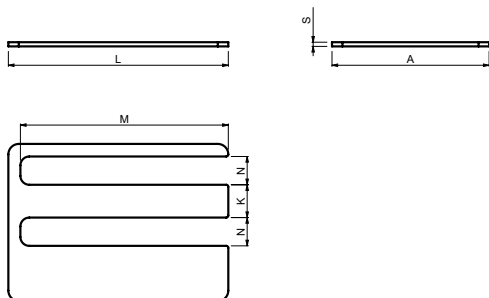
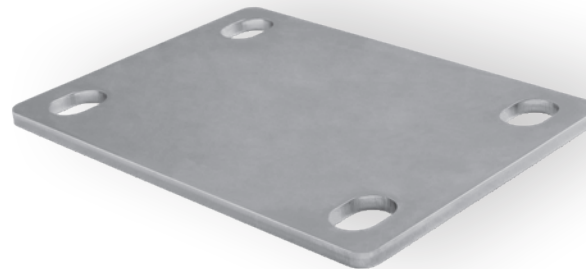
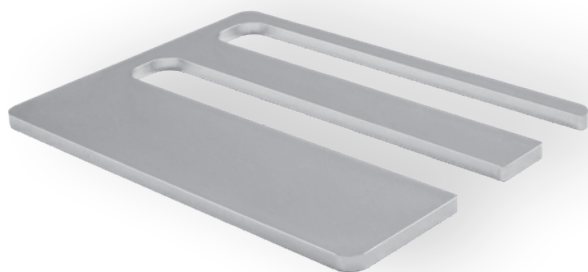

- (GB) WASHER FOR CANTILEVER CARRIAGE
- (D) UNTERLEGSCHIBE FÜR AUSLEGERSCHLITTEN
- (F) RONDELLE POUR CHARIOT CANTILEVER
- (E) TUERCA PARA CARRO EN VOLADIZO
- (P) ARRUELA PARA TRANSPORTE DE CANTILEVER
- (I) RONDELLA PER CARRELLO CANCELLO AUTOPORTANTE
- (DK) SKIVE TIL FRITBÆRENDE PORT
- (NL) RING VOOR SCHUIFWAGEN
- (N) SKIVE FOR RULLEPORTVOGN
- (S) BRICKA FÖR FRIBÄRANDE GRINDVAGN
- (FIN) ALUSLEVY ULOKETELINEESEEN
- (PL) PODKŁADKA DO WÓZKA BRAMY SAMONOŚNEJ
- (SK) PODLOŽKA PRE SAMONOSNÝ NOSNÍK
- (EE) SEIB KONSOOLALUSE JAOKS
- (LT) POVERŽLĖ GEMBINIŲ VARTŲ VEŽIMĖLIUI
- (LV) PĀPLĀKSNE KONSOLES NESOŠAJAM RUĻĻU BLOKAM

- (CZ) PODLOŽKA PRO VOZÍK
- (RO) ȘAIBĂ PENTRU SISTEMUL DE CULISARE ÎN CONSOLĂ
- (HR) PODLOŠKA ZA NOSIVO PODVOZJE
- (RUS) ШАЙБА ДЛЯ РОЛИКОВЫХ ТЕЛЕЖЕК САМОНЕСУЩИХ ВОРОТ
- (SLO) PODLOŽKA ZA VOZIČEK
- (TR) MANİVELA TAŞIYICISI İÇİN RONDELA
- (AR) حلبة ليوابة الكارول
- (CHN) 悬臂架垫片
- (MAL) SESENDAL UNTUK PEMBAWA JULUR
- (H) ALÁTÉT TOLÓKAPU FUTÓKOCSIHOZ
- (IL) חקרה לגלגלים לקרונוז'ו
- (BG) ВЛОЖКА ЗА КОНЗОЛНА КОЛИЧКА
- (KO) 캔틸레버 이송대용 와셔
- (SRB) PODLOŠKA ZA SAMONOSIVU KAPIJU

- (GB) WASHER FOR CANTILEVER CARRIAGE
- (D) UNTERLEGSCHIBE FÜR AUSLEGERSCHLITTEN
- (F) RONDELLE POUR CHARIOT CANTILEVER
- (E) TUERCA PARA CARRO EN VOLADIZO
- (P) ARRUELA PARA TRANSPORTE DE CANTILEVER
- (I) RONDELLA PER CARRELLO CANCELLO AUTOPORTANTE
- (DK) SKIVE TIL FRITBÆRENDE PORT
- (NL) RING VOOR SCHUIFWAGEN
- (N) SKIVE FOR RULLEPORTVOGN
- (S) BRICKA FÖR FRIBÄRANDE GRINDVAGN
- (FIN) ALUSLEVY ULOKETELINEESEEN
- (PL) PODKŁADKA DO WÓZKA BRAMY SAMONOŚNEJ
- (SK) PODLOŽKA PRE SAMONOSNÝ NOSNÍK
- (EE) SEIB KONSOOLALUSE JAOKS
- (LT) POVERŽLĖ GEMBINIŲ VARTŲ VEŽIMĖLIUI
- (LV) PĀPLĀKSNE KONSOLES NESOŠAJAM RUĻĻU BLOKAM

- (CZ) PODLOŽKA PRO VOZÍK
- (RO) ȘAIBĂ PENTRU SISTEMUL DE CULISARE ÎN CONSOLĂ
- (HR) PODLOŠKA ZA NOSIVO PODVOZJE
- (RUS) ШАЙБА ДЛЯ РОЛИКОВЫХ ТЕЛЕЖЕК САМОНЕСУЩИХ ВОРОТ
- (SLO) PODLOŽKA ZA VOZIČEK
- (TR) MANİVELA TAŞIYICISI İÇİN RONDELA
- (AR) حلبة ليوابة الكارول
- (CHN) 悬臂架垫片
- (MAL) SESENDAL UNTUK PEMBAWA JULUR
- (H) ALÁTÉT TOLÓKAPU FUTÓKOCSIHOZ
- (IL) חקרה לגלגלים לקרונוז'ו
- (BG) ВЛОЖКА ЗА КОНЗОЛНА КОЛИЧКА
- (KO) 캔틸레버 이송대용 와셔
- (SRB) PODLOŠKA ZA SAMONOSIVU KAPIJU

Art.	L	A	K	M	N	S	CARRIAGE	1pc				CODE
									kg	pcs	kg	
	mm											
<b>DESK MEK 2</b>	210	150	72	199	27	2	SPEED MEK	0,32	4	1,28	1700329	
<b>DESK MEK 4</b>	210	150	72	199	27	4	SPEED MEK	0,64	4	2,56	1700330	
<b>DESK MEK 6</b>	210	150	72	199	27	6	SPEED MEK	0,96	4	3,84	1700331	

Art.	L	A	J	K1	K2	M	N	S	CARRIAGE	1pc				CODE
											kg	pcs	kg	
	mm													
<b>RAMP ME 2</b>	210	150	17x27	170	99	20	25,5	2	SPEED ME	0,48	4	1,92	1700292	
<b>RAMP ME 4</b>	210	150	17x27	170	99	20	25,5	4	SPEED ME	0,89	4	3,56	1700293	
<b>RAMP ME 6</b>	210	150	17x27	170	99	20	25,5	6	SPEED ME	1,34	4	5,36	1700294	

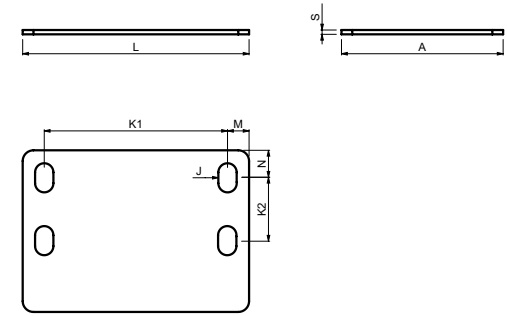
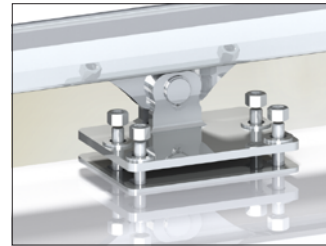
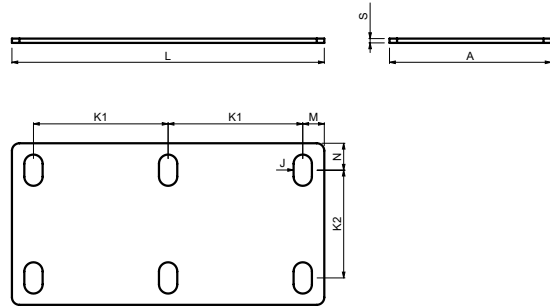
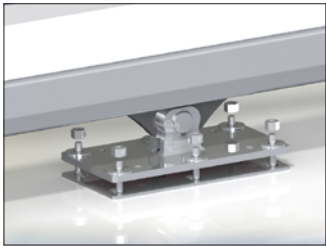
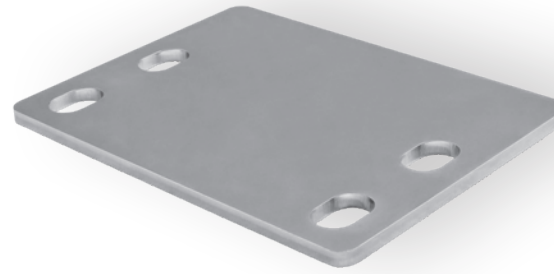

- (GB) WASHER FOR CANTILEVER CARRIAGE
- (D) UNTERLEGSCHIEBE FÜR AUSLEGERSCHLITTEN
- (F) RONDELLE POUR CHARIOT CANTILEVER
- (E) TUERCA PARA CARRO EN VOLADIZO
- (P) ARRUELA PARA TRANSPORTE DE CANTILEVER
- (I) RONDELLA PER CARRELLO CANCELLO AUTOPORTANTE
- (DK) SKIVE TIL FRITBÆRENDE PORT
- (NL) RING VOOR SCHUIFWAGEN
- (N) SKIVE FOR RULLEPORTVOGN
- (S) BRICKA FÖR FRIBÄRANDE GRINDVAGN
- (FIN) ALUSLEVY ULOKETELINEESEEN
- (PL) PODKŁADKA DO WÓZKA BRAMY SAMONOŚNEJ
- (SK) PODLOŽKA PRE SAMONOSNÝ NOSNÍK
- (EE) SEIB KONSOOLALUSE JAOKS
- (LT) POVERŽLĖ GEMBINIŲ VARTŲ VEŽIMĖLIUI
- (LV) PĀPLĀKSNE KONSOLES NESOŠAJAM RUĻĻU BLOKAM

- (CZ) PODLOŽKA PRO VOZÍK
- (RO) ȘAIBĂ PENTRU SISTEMUL DE CULISARE ÎN CONSOLĂ
- (HR) PODLOŠKA ZA NOSIVO PODVOZJE
- (RUS) ШАЙБА ДЛЯ РОЛИКОВЫХ ТЕЛЕЖЕК САМОНЕСУЩИХ ВОРОТ
- (SLO) PODLOŽKA ZA VOZIČEK
- (TR) MANIVELA TAŞIYICISI İÇİN RONDELA
- (AR) حلبة لولاية الكابول
- (CHN) 悬臂架垫片
- (MAL) SESENDAL UNTUK PEMBAWA JULUR
- (H) ALÁTÉT TOLÓKAPU FUTÓKOCSIHOZ
- (IL) חוקה לגלגלים לקונזול
- (BG) ВЛОЖКА ЗА КОНЗОЛНА КОЛИЧКА
- (KO) 캔틸레버 이송대용 와셔
- (SRB) PODLOŠKA ZA SAMONOSIVU KAPIJU

- (GB) WASHER FOR CANTILEVER CARRIAGE
- (D) UNTERLEGSCHIEBE FÜR AUSLEGERSCHLITTEN
- (F) RONDELLE POUR CHARIOT CANTILEVER
- (E) TUERCA PARA CARRO EN VOLADIZO
- (P) ARRUELA PARA TRANSPORTE DE CANTILEVER
- (I) RONDELLA PER CARRELLO CANCELLO AUTOPORTANTE
- (DK) SKIVE TIL FRITBÆRENDE PORT
- (NL) RING VOOR SCHUIFWAGEN
- (N) SKIVE FOR RULLEPORTVOGN
- (S) BRICKA FÖR FRIBÄRANDE GRINDVAGN
- (FIN) ALUSLEVY ULOKETELINEESEEN
- (PL) PODKŁADKA DO WÓZKA BRAMY SAMONOŚNEJ
- (SK) PODLOŽKA PRE SAMONOSNÝ NOSNÍK
- (EE) SEIB KONSOOLALUSE JAOKS
- (LT) POVERŽLĖ GEMBINIŲ VARTŲ VEŽIMĖLIUI
- (LV) PĀPLĀKSNE KONSOLES NESOŠAJAM RUĻĻU BLOKAM

- (CZ) PODLOŽKA PRO VOZÍK
- (RO) ȘAIBĂ PENTRU SISTEMUL DE CULISARE ÎN CONSOLĂ
- (HR) PODLOŠKA ZA NOSIVO PODVOZJE
- (RUS) ШАЙБА ДЛЯ РОЛИКОВЫХ ТЕЛЕЖЕК САМОНЕСУЩИХ ВОРОТ
- (SLO) PODLOŽKA ZA VOZIČEK
- (TR) MANIVELA TAŞIYICISI İÇİN RONDELA
- (AR) حلبة لولاية الكابول
- (CHN) 悬臂架垫片
- (MAL) SESENDAL UNTUK PEMBAWA JULUR
- (H) ALÁTÉT TOLÓKAPU FUTÓKOCSIHOZ
- (IL) חוקה לגלגלים לקונזול
- (BG) ВЛОЖКА ЗА КОНЗОЛНА КОЛИЧКА
- (KO) 캔틸레버 이송대용 와셔
- (SRB) PODLOŠKA ZA SAMONOSIVU KAPIJU

Art.	L	A	J	K1	K2	M	N	S	CARRIAGE	1pc				CODE
											kg	pcs	kg	
mm														
<b>RAMP M 2</b>	290	150	17x27	125	99	20	25,5	2	SPEED M	0,65	4	2,6	1700295	
<b>RAMP M 4</b>	290	150	17x27	125	99	20	25,5	4	SPEED M	1,23	4	4,92	1700296	
<b>RAMP M 6</b>	290	150	17x27	125	99	20	25,5	6	SPEED M	1,85	4	7,4	1700297	

Art.	L	A	J	K1	K2	M	N	S	CARRIAGE	1pc				CODE
											kg	pcs	kg	
mm														
<b>RAMP MEK 2</b>	210	150	17x27	170	65	20	25,5	2	SPEED MEK	0,48	4	1,92	1700298	
<b>RAMP MEK 4</b>	210	150	17x27	170	65	20	25,5	4	SPEED MEK	0,89	4	3,56	1700299	
<b>RAMP MEK 6</b>	210	150	17x27	170	65	20	25,5	6	SPEED MEK	1,34	4	5,36	1700300	

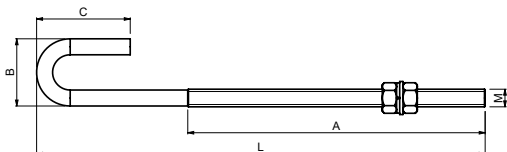
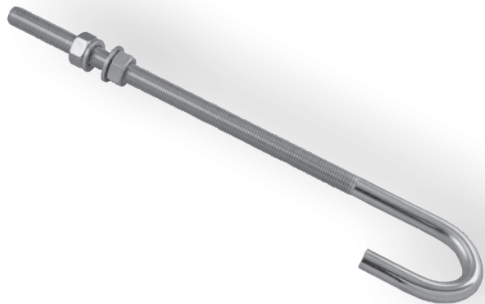

- (GB) FIXING BAR FOR CANTILEVER CARRIAGE
- (D) BEFESTIGUNGSSTANGE FÜR AUSLEGERSCHLITTEN
- (F) BARRE DE FIXATION POUR CHARIOT CANTILEVER
- (E) BARRA DE FIJACIÓN PARA CARRO EN VOLADIZO
- (P) BARRA DE FIXAÇÃO DE TRANSPORTE DE CANTILEVER
- (I) BARRA DI FISSAGGIO PER CARRELLO CANCELLO AUTOPORTANTE
- (DK) FASTGØRELSESSTANG TIL FRITBÆRENDE PORT
- (NL) BEVESTIGINGSBALK VOOR SCHUIFWAGEN
- (N) FESTSTANG FOR RULLEPORT
- (S) FÅSTBALK FÖR FRIBÄRANDE GRINDVAGN
- (FIN) KIINNITYSPALKKI ULOKETELINEESEEN
- (PL) LISTWA MOCUJĄCA DO WÓZKA BRAMY SAMONOŚNEJ
- (SK) UPEVNŔOVACIA TYČ PRE SAMONOSNÝ NOSNÍK
- (EE) FIKSEERIMISTALA KONSOLALUSE JAOKS
- (LT) TVIRTINIMO STRYPAS GEMBINIŲ VARTŲ VEŽIMĖLIUI
- (LV) FIKSĒJOŠAIS STIENIS KONSOLĒSAM RUČĻU BLOKAM

- (CZ) FIXNÍ TYČ PRO VOZÍK
- (RO) BARĂ DE FIXARE PENTRU SISTEMUL DE CULISARE ÎN CONSOLĂ
- (HR) FIKSIRAJUĆA ŠIPKA ZA NOSIVO PODVOZJE
- (RUS) КРЕПЕЖНЫЙ СТЕРЖЕНЬ ДЛЯ РОЛИКОВЫХ ТЕЛЕЖЕК САМОНЕСУЩИХ ВОРОТ
- (SLO) PRITRDILNI DROG ZA VOZIČEK
- (TR) MANİVELA TAŞIYICISI İÇİN SABİTLEME ÇUBUĞU
- (AR) قضيب التثبيت لوابية الكابول
- (CHN) 悬臂架固定条
- (MAL) BAR IKATAN UNTUK PEMBAWA JULUR
- (H) RÖGZÍTŐRÚD TOLÓKAPU FUTÓKOSÍHOZ
- (IL) מסך קיבוע לגלגלי מ ל קונזולי
- (BG) ФИКСАТОР ЗА КОНЗОЛНА КОЛИЧКА
- (KO) 캔틸레버 이송대용 고정대
- (SRB) FIKSIRAJUĆA ŠIPKA ZA SAMONOSIVU KAPIJU

Art.	L	A	B	C	M	WASHER	1pc	WASHER			CODE
								kg	pcs	kg	
			mm								
<b>CLINCH 16</b>	410	300	60	80	M16	RAMP	0,72	12	8,64		1700239

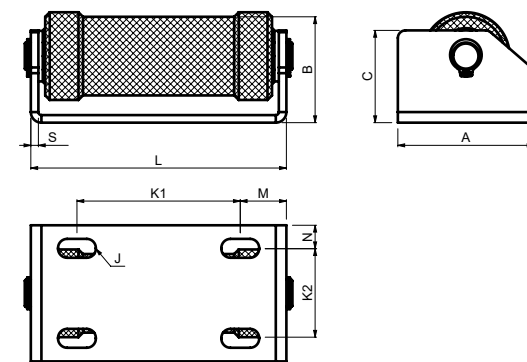
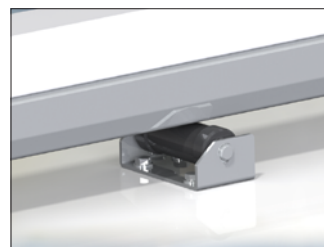
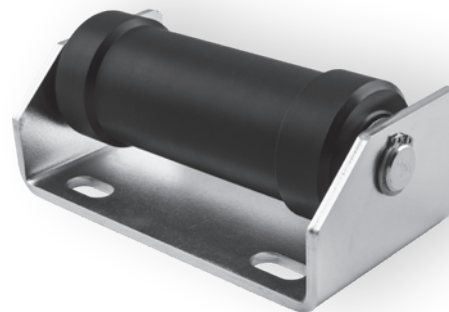

- (GB) SUPPORT ROLLER FOR CANTILEVER GATE
- (D) STÜTZROLLE FÜR AUSLEGERGERT
- (F) ROULEAU DE SUPPORT POUR PORTAIL COULISSANT AUTOPORTANT
- (E) RODILLO DE SOPORTE PARA PORTÓN EN VOLADIZO
- (P) ROLO DE SUPORTE PARA PORTÃO DE CANTILEVER
- (I) RULLO DI SOSTEGNO PER CANCELLO AUTOPORTANTE
- (DK) STØTTERULLE TIL FRITBÆRENDE PORT
- (NL) STEUNROL VOOR SCHUIFPOORT
- (N) STØTTERULLE FOR RULLEPORT
- (S) STÖDROLLE FÖR FRIBÄRANDE GRIND
- (FIN) TUKIRULLA ULOKEPORTTIIN
- (PL) ROLKA DOLNA DO BRAMY SAMONOŚNEJ
- (SK) PODPORNÝ VALEC PRE SAMONOSNÉ BRÁNY
- (EE) TUGIRULLIK KONSOLVÄRAVA JAOKS
- (LT) ATRAMINIS RITINĖLIS GEMBINIAMS VARTAMS
- (LV) BALSTA RULLĪTIS KONSOLVEIDA VĀRTIEM

- (CZ) KONZOLA S KLDKOU PRO PODPĚRU POSUVNÉ SAMONOSNÉ BRÁNY
- (RO) ROLĂ DE SUSȚINERE PENTRU POARTA ÎN CONSOLĂ
- (HR) POTPORNİ VALJAK ZA NOSIVA VRATA
- (RUS) ОПОРНЫЙ РОЛИК ДЛЯ САМОНЕСУЩИХ ВОРОТ
- (SLO) PODPORNİ VALJ ZA SAMONOSNA DRSNİ VRATA
- (TR) MANİVELA KAPİ İÇİN DESTEK MAKARASİ
- (AR) اسطوانة الدعم لوابية الكابول
- (CHN) 悬臂门支撑轮
- (MAL) PENGGELEK SOKONGAN UNTUK GET JULUR
- (H) TARTÓGÖRGŐ TOLÓKAPUHOZ
- (IL) גלגל תמיכה לשער קונזולי
- (BG) ПОДДЪРЖАЩА РОЛКА ЗА КОНЗОЛНА ВРАТА
- (KO) 캔틸레버 게이트용 지지 롤러
- (SRB) NOSEČI VALJAK ZA SAMONOSIVU KAPIJU

Art.	L	A	B	C	J	K1	K2	M	N	S	1pc	WASHER			CODE
												kg	pcs	kg	
			mm												
<b>DRIVESHAFT 80</b>	144	90	70	73	13x25	107	60	31	15	5	1,37	4	5,48		1700332
<b>DRIVESHAFT 100</b>	169	90	70	73	13x25	107	60	31	15	5	1,56	4	6,24		1700333

DESIGNED FOR STRAIGHT ROLLING MOVEMENT



# EASY SETS



16  
FOLLOW ME



18  
TWIN DRIVE

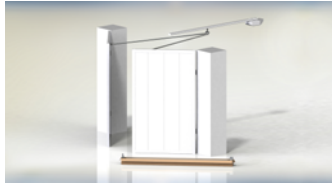

20  
CHEVRON

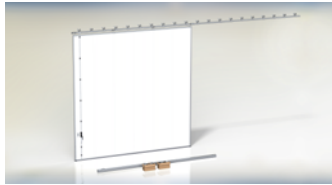

22  
HANGAR



24  
ALL IN ONE



# CANTILEVER S



39  
STAGE SB



39  
STAGE SZ



40  
SPEED SE



40  
SPEED S



41  
SPEED SK



41  
RUN S



42  
LAST S



42  
PARK



42  
PARK 240



43  
Paddock SM



43  
PILOT SN



44  
Paddock 2



44  
Paddock 4

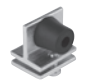

45  
FINISH S



45  
DIAGON 60



45  
DIAGON 80



46  
DESK SE



46  
DESK S



47  
DESK SK



47  
RAMP SE



48  
RAMP S



48  
RAMP SK



49  
CLINCH 16



49  
DRIVESHAFT 80



49  
DRIVESHAFT 100



# CANTILEVER M



57  
STAGE MB



57  
STAGE MZ



58  
SPEED ME



58  
SPEED M



59  
SPEED MEK



59  
RUN M



60  
LAST M



60  
PARK



60  
PARK 240



61  
Paddock SM



61  
PILOT M



61  
PILOT MN



62  
Paddock 2



62  
Paddock 4



63  
FINISH M



63  
DIAGON 60



63  
DIAGON 80



64  
DESK ME



64  
DESK M



65  
DESK MEK



65  
RAMP ME



66  
RAMP M



66  
RAMP MEK



67  
CLINCH 16



67  
DRIVESHAFT 80



67  
DRIVESHAFT 100



# CANTILEVER L



70  
STAGE LB



70  
STAGE LZ



71  
SPEED L



71  
PILOT L



71  
PILOT LN



72  
RUN L



72  
LAST L



73  
PARK L



73  
PARK L 350



73  
DRIVESHAFT 150



74  
Paddock L



74  
Paddock 6



75  
RAMP L



75  
CLINCH 16











































































# CANTILEVER SETS



26  
SOLE  
MARE  
VITA  
FERRO  
DINO  
ENZO  
DEMO



	<b>78</b> TRAIL		<b>82</b> WV 1228 B2		<b>84</b> WTV 1024 B2		<b>87</b> WSO 1024		<b>88</b> RB 32		<b>92</b> SFB 42/16		<b>98</b> LOCK L		<b>102</b> LIMIT
	<b>78</b> PIN TRAIL		<b>82</b> WV 1430 B2		<b>85</b> WTO 625		<b>87</b> WSO 824 B2		<b>88</b> RB 42/16		<b>92</b> SFF 2M		<b>96</b> DOCK 42		<b>102</b> LIMIT S
	<b>79</b> ROAD		<b>82</b> WV 1630 B2		<b>85</b> WTO 825		<b>87</b> WSO 924 B2		<b>88</b> RB 42/20		<b>93</b> SFG 4M		<b>98</b> DOCK 52		<b>103</b> LIMIT M
	<b>79</b> PIN ROAD		<b>83</b> WO 824		<b>85</b> WTO 1024 B2		<b>87</b> WSO 1024 B2		<b>89</b> ROB 36		<b>93</b> CRANKSHAFT 220		<b>98</b> DOCK 62		<b>103</b> LIMIT H
	<b>80</b> VECTOR		<b>83</b> WO 924		<b>86</b> WSV 820		<b>87</b> WSO 1228 B2		<b>89</b> ROB 48		<b>93</b> CRANKSHAFT 440		<b>99</b> V/6		<b>104</b> ES 40
	<b>80</b> PIN VECTOR		<b>83</b> WO 1024		<b>86</b> WSV 920		<b>87</b> WSO 1630 B2		<b>89</b> ROB 68		<b>94</b> JRS 30		<b>99</b> S/6		<b>104</b> ES 50
	<b>81</b> VECTOR PACK		<b>83</b> WO 824 B2		<b>86</b> WSV 1020		<b>88</b> RW 26		<b>89</b> REB 36		<b>94</b> JRM 40		<b>99</b> Z/8		<b>104</b> ES 40 PN
	<b>82</b> WV 620		<b>83</b> WO 924 B2		<b>86</b> WSV 824 B2		<b>88</b> RW 30		<b>89</b> REB 48		<b>94</b> PRS 30		<b>99</b> Z/12		<b>104</b> ES 50 PN
	<b>82</b> WV 820		<b>83</b> WO 1024 B2		<b>86</b> WSV 924 B2		<b>88</b> RW 40		<b>89</b> REB 68		<b>94</b> PRM 40		<b>100</b> ROOF B		<b>105</b> END S
	<b>82</b> WV 920		<b>83</b> WO 1228 B2		<b>86</b> WSV 1024 B2		<b>88</b> RR 26		<b>90</b> SR 2		<b>95</b> DRIVER 38		<b>100</b> ROOF S		<b>105</b> END M
	<b>82</b> WV 1020		<b>83</b> WO 1430 B2		<b>86</b> WSV 1228 B2		<b>88</b> RR 30		<b>90</b> FRS 2		<b>95</b> DRIVER 48		<b>101</b> DUNE 2		<b>105</b> END L
	<b>82</b> WV 824 B2		<b>83</b> WO 1630 B2		<b>86</b> WSV 1630 B2		<b>88</b> RR 40		<b>90</b> FRM 2				<b>101</b> DUNE 2L		<b>105</b> END O
	<b>82</b> WV 924 B2		<b>84</b> WTV 624		<b>87</b> WSO 824		<b>88</b> RB 26		<b>91</b> GRS 4						
	<b>82</b> WV 1024 B2		<b>84</b> WTV 824		<b>87</b> WSO 924		<b>88</b> RB 30		<b>91</b> GRM 4						

	<b>108</b> H 18		<b>110</b> HW 18		<b>113</b> AB 50 LSU
	<b>108</b> H 20		<b>110</b> HW 20		<b>113</b> AB 70 LSU
	<b>108</b> H 24		<b>110</b> HW 24		<b>113</b> AB 50 ASU
	<b>108</b> HN 18		<b>111</b> HL 20		<b>113</b> AB 70 ASU
	<b>108</b> HN 20		<b>111</b> HL 24		<b>114</b> H 40
	<b>108</b> HN 24		<b>111</b> HL 20 G		<b>114</b> HN 40
	<b>109</b> HP 18 R		<b>111</b> HL 24 G		<b>115</b> HP 40 S
	<b>109</b> HP 20 S		<b>112</b> AB 50 L		<b>115</b> HP 40
	<b>109</b> HP 24 S		<b>112</b> AB 70 L		<b>116</b> SH 20
	<b>110</b> HP 18 O		<b>112</b> AB 50 A		<b>116</b> SH 24
	<b>110</b> HP 20 SO		<b>112</b> AB 70 A		

	<b>120</b> STRELA 33
	<b>120</b> STRELA 42
	<b>120</b> STRELA 57
	<b>121</b> 2 SBK
	<b>121</b> 2 SAK
	<b>121</b> 4 SBK
	<b>121</b> 4 SAK
	<b>122</b> DB 33
	<b>122</b> DB 42
	<b>122</b> DB 57
	<b>122</b> DH 33
	<b>122</b> DH 42

	<b>122</b> DH 57
	<b>123</b> AG 33
	<b>123</b> AG 42
	<b>123</b> AG 57
	<b>123</b> FINISH 33
	<b>123</b> FINISH 42
	<b>123</b> FINISH 57
	<b>124</b> DM 8
	<b>124</b> DM 12
	<b>124</b> DM 20
	<b>124</b> 4 SCML
	<b>125</b> 2 SCF

	<b>125</b> 4 SCF
	<b>126</b> 2 SC
	<b>126</b> 4 SC
	<b>127</b> 2 SCTS
	<b>127</b> 2 SCTL
	<b>127</b> SCTS
	<b>127</b> SCTL
	<b>131</b> MCD 60
	<b>131</b> AD 150
	<b>132</b> SPEED C
	<b>132</b> STAGE SZ
	<b>133</b> DC 70

	<b>133</b> KHL 140
	<b>133</b> KHL 180
	<b>134</b> DF 190
	<b>134</b> FINISH S
	<b>135</b> RS 25
	<b>135</b> RS 40
	<b>136</b> KL 70 L
	<b>136</b> KL 70 R
	<b>136</b> TL 30
	<b>137</b> TL 40
	<b>137</b> TL 70
	<b>138</b> TL 50

	<b>138</b> TL 90
	<b>139</b> AD 25
	<b>139</b> AS 25
	<b>139</b> AR 25
	<b>139</b> BD 25
	<b>139</b> BD 35
	<b>139</b> BD 45
	<b>140</b> MS 40
	<b>140</b> GD 180

# About Us

We are dedicated to making the best cantilever and sliding gate hardware. Since inception direction towards to the highest quality is our driving force. This can be seen with the dedication and passion of the workforce. This can be seen in the packaging. This can be seen in the care and attention to the smallest details. As it's this detail on hardware that can make all the difference in the lifespan of the product and the electric motors that power them.

Following extensive research and development **CAIS** is now in the enviable position of offering the highest quality product available for the gate market. We have worked with a renowned BRNO UNIVERSITY OF TECHNOLOGY - FACULTY OF MECHANICAL ENGINEERING, looking at the way the load is transferred throughout the wheels, bearings and carriages whilst under stress of a moving gate.

The results surprised and inspired us to reinvent our product, to become more accurate and search intensively for a steel supplier that can match our ambitions.

We searched for galvanised steel that doesn't crack under rolling, we searched for steel of the correct tolerances and chemical composition.

We found all this and more with our German Supplier WUPPERMANN and created something very impressive.

CAIS also invested heavily in what is the heart of our company, a brand new roll forming line.

With uniquely, 18 large precision formed rollers that allow minute differences to be made until the rolling is perfectly straight and accurate to our own exact standards.



## State Of The Art Roll Forming Line

**Eighteen Roll Formers** - The best in the industry to remove the inset "memory" of the metal.

**Built in flying hole punch** - Punches a hole in the rail exactly every 400 mm.

**Slow rolling** - This means no heat during the production keeping the material where it is rolled with no "relaxation" of the product after.

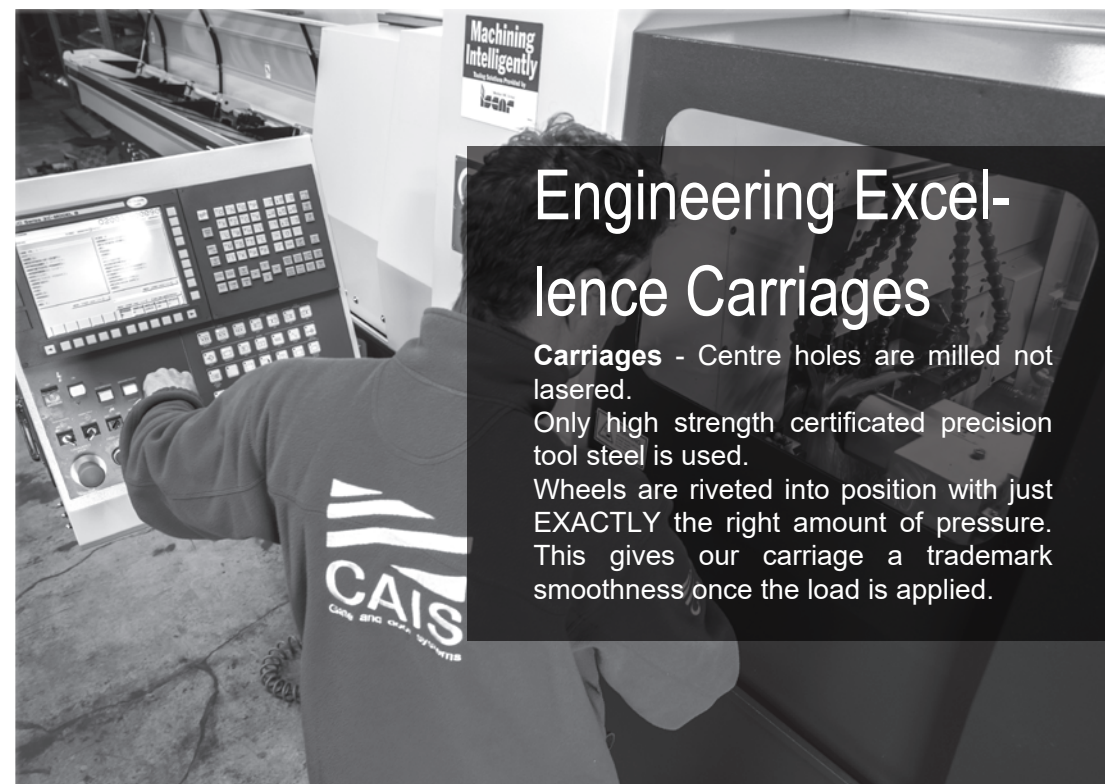

## Engineering Excellence Carriages

**Carriages** - Centre holes are milled not lasered.

Only high strength certificated precision tool steel is used.

Wheels are riveted into position with just EXACTLY the right amount of pressure.

This gives our carriage a trademark smoothness once the load is applied.



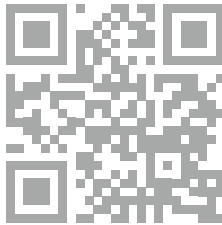

[www.cais.eu](http://www.cais.eu)