

START-S19XL RED

TECHNICAL MANUAL

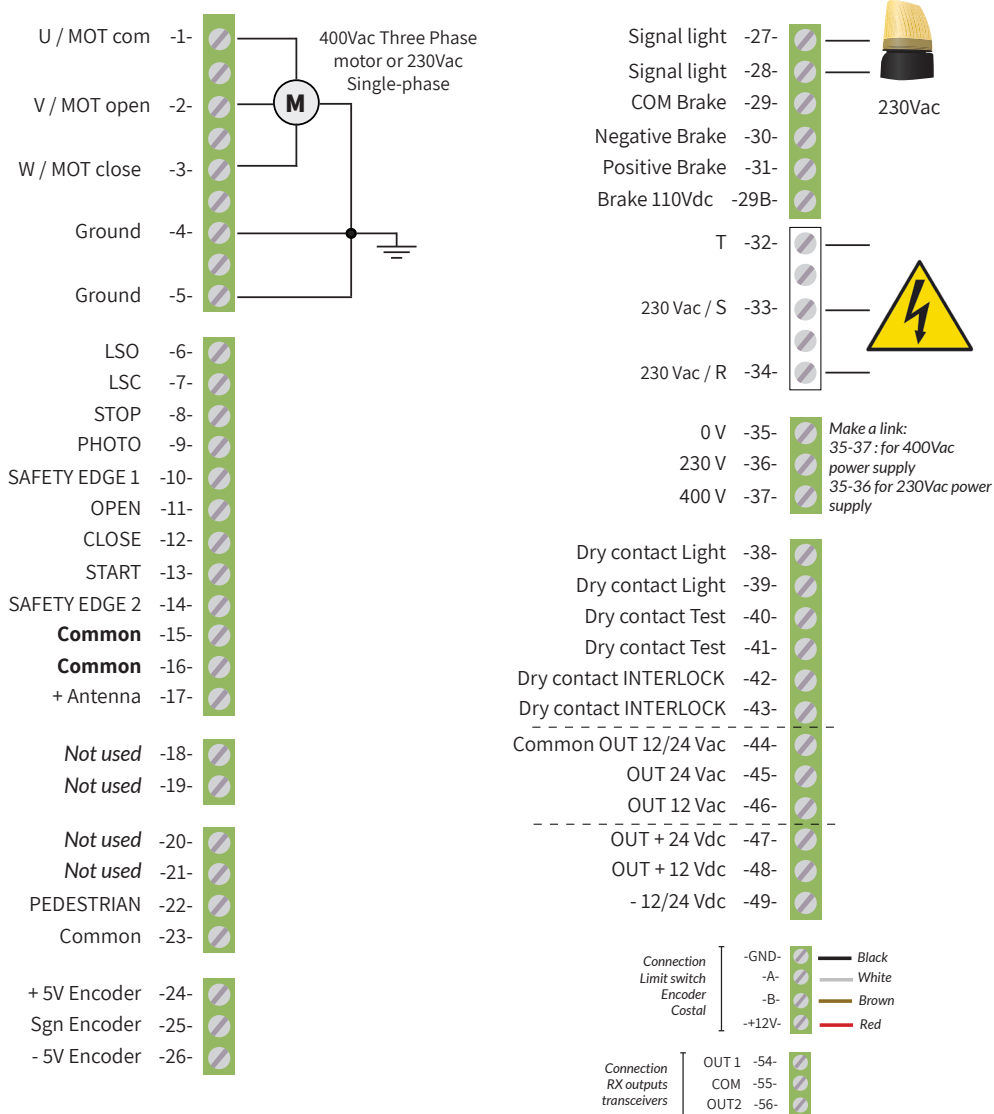

SYMBOL

The special messages indicated below, may appear throughout the technical manual to draw attention to information that clarifies or simplifies a procedure.



The addition of this graphic symbol to a “Danger” or “Warning” safety advice, indicates that there is an electrical or mechanical risk, which can cause physical injury if the instructions are not followed. Please follow all safety messages that have this symbol to avoid injury or material damage.



Damage! For safety reasons, protect your face during the connection.

WARNING

Installation, management, service and maintenance must only be carried out by qualified personnel. The producer assumes no responsibility for the consequences that may arise from the use of this material. Failure to follow these instructions can result in serious personal injury.

INTRODUCTION

This manual provides all the information necessary for the correct installation and use of the equipment in your possession. It must be read carefully at the time of purchase, and consulted to check the limitations on the use, and when you are about to carry out maintenance. The manufacturer reserves the right to make any changes to the product without notice.

SAFETY MEASURE

In the event of incorrect use, repairs or modifications made by unqualified personnel, all guarantees will be void. The manufacturer declines all responsibility for damage deriving from inappropriate use of the product or from use other than that for which the product was intended. The manufacturer declines all responsibility for consequential damages except for the civil liability for the products. We remind you that automatic gate and door systems must only be installed by qualified technical personnel, in full compliance with the law. Before each installation check the mechanical strength of the gate or door. Check that all mechanical stops are suitable to stop the gate/door to avoid of damage.

MEASURE FOR THE ENVIRONMENT

In the event of incorrect use, repairs or modifications made by unqualified personnel, all guarantees will be void. The manufacturer declines all responsibility for damage deriving from inappropriate use of the product or from use other than that for which the product was intended. The manufacturer declines all responsibility for consequential damages except for the civil liability for the products. We remind you that automatic gate and door systems must only be installed by qualified technical personnel, in full compliance with the law. Before each installation check the mechanical strength of the gate or door. Check that all mechanical stops are suitable to stop the gate/door to avoid of damage.

INDEX

1. INTRODUCTION	3
1.1 SAFETY PRECAUTIONS	3
1.2 FIELD OF APPLICATION	3
1.3 TYPE OF INSTALLATION	3
1.4 TECHNICAL FEATURES	3
2. INSTALLATION	4
2.1 DIAGRAM OF THE CONTROL UNIT AND ELECTRICAL CONNECTIONS	4
2.2 CONNECTION OF THE POWER SUPPLY	5
2.3 CONNECTION OF THE MOTOR	5
2.1 CONNECTION OF A 230 VAC SIGNAL LIGHT	5
2.4 PRE-LIGHTING	5
2.5 CONNECTION OF A 24V LIGHT FOR OPEN OR MOVING GATE	6
2.6 CONNECTION OF THE LSC AND LSC	6
2.7 POWER SUPPLY FOR ACCESSORIES	6
2.8 CONNECTION OF STOP DEVICES	7
2.9 CONNECTION OF THE START COMMAND	7
2.10 CONNECTION OF A PARTIAL OPENING	7
2.11 CONNECTION OF THE ANTENNA	7
2.12 CONNECTION OF THE PHOTOCELLS (ONLY CLOSE) 24 VAC	8
2.13 CONNECTION OF THE SECURITY OR ANTI-FOLD UP	9
2.14 OPENING / CLOSING IN CASE OF EMERGENCY	9
3. USE AND FUNCTIONS OF THE CONTROL PANEL	10
3.1 SETTINGS AND PARAMETERS	10
3.2 EXAMPLE HOW TO USE THE MENU AND INFORMATION	11
3.3 SET UP A PASSWORD FOR PROGRAMMING	12
4. ACTIVATE THE SINGLE OUTPUTS	13
5. FUNCTIONS AND ADJUSTMENT	15
5.1 LOGIC OF FUNCTIONS	15
5.2 FUNCTIONS AND ADJUSTMENT	16
5.3 SET UP OF SPEED AND ACCELERATION	17
5.4 CONNECTION OF RX RADIO BAND (AVAILABLE ON REQUEST)	17
5.6 MEMORIZATION OF THE ENCODER KOSTAL	18
6. RESTORE OF FACTORY DEFAULT SETTINGS	19
6.1 RESTORE FACTORY SETTINGS	19
6.1 SAVE AND CHECK OF THE PARAMETERS	20
7. TROUBLESHOOTING	20
8. INSTALLATION	21
8.1 GROUP S	21
8.2 GROUP R	22
8.3 GROUP T	23
8.4 GROUP L	23
9. DECLARATION OF CE CONFORMITY	24

1. INTRODUCTION

1.1 SAFETY PRECAUTIONS

Using the unit improperly and performing repairs or modifications personally will void the warranty. The producer declines any responsibility for damages due to inappropriate use of the product and due to any use other than the use the product was designed for. The producer declines any responsibility for consequential damages except civil liability for the products. Every programming and/or every maintenance service should be done by qualified technicians.

1.2 FIELD OF APPLICATION

Control unit for check the phases, for 1 single-and-three phase motor up to 2HP for industrial rapid unfolding doors and industrial sliding gates. The control unit START S19XL checks the right power nad phase before the cycle. Encoder connection.

1.3 TYPE OF INSTALLATION

These two simple diagrams show only one of the possible applications for this control unit. The risks inherent to the “MACHINE” and the user’s requirements must be analyzed in depth in order to establish how many elements need to be installed. All photocells have a system of synchronism that makes it possible to eliminate interference between two pairs of photocells (for other details, see the instructions for the photocells). In the diagram, the pair of photocells “Photo A” (considered in this control unit) has no effect during opening while it causes a total inversion during closing. “Photo A2” is connected in series to “Photo A”.

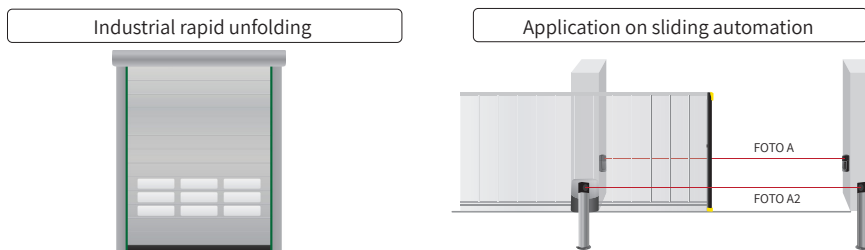

We recommend to install a STOP switch which stops immediately the gate. The switch has a normally close contact which opens the contact when it is working. See Par. 2.7

1.4 TECHNICAL FEATURES

Dimensions	190 x 200 x 65	mm
Weight	1,450	Kg
MAX power of single motor	2 1500	HP W
MAX power of signal light 230 Vac	40	W
MAX absorption with clean contact	5	A
MAX absorption 24 Vac	300	mA
MAX absorption 12 Vac/dc	50	mA
MAX absorption 24 Vdc	50	mA

2. INSTALLATION

2.1 DIAGRAM OF THE CONTROL UNIT AND ELECTRICAL CONNECTIONS

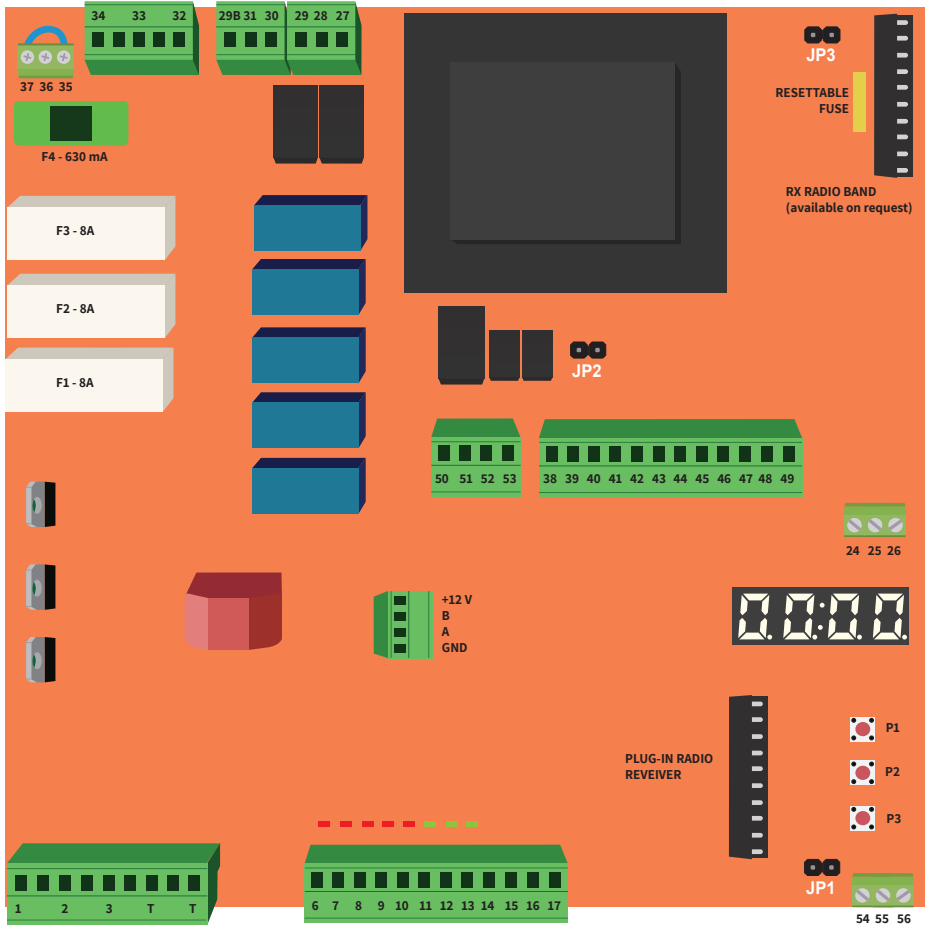

START-S19XL make a test of the correct running of the power, when the control pane is switched on the control panel make a test and these are the results:



Single-phase connection



Three-phase connection
R-S-T in the correct sequence



Three-phase connection R-S-T with reversed sequence (the control panel reverses automatically OPEN and CLOSE of the motor)

2.2 CONNECTION OF THE POWER SUPPLY

There are three possibilities to power the control unit:

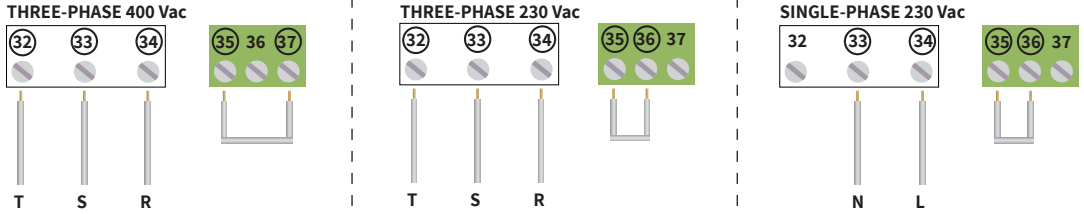

The voltage line must be protected from a thermal-cutoff-switch or from a 5A fuse. A circuit-breaker is recommended but not necessary if not available in the installation

2.3 CONNECTION OF THE MOTOR

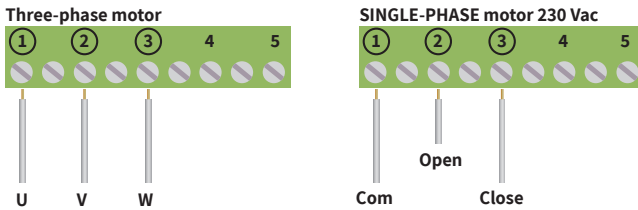

2.1 CONNECTION OF A 230 VAC SIGNAL LIGHT

• With intermittence circuit board

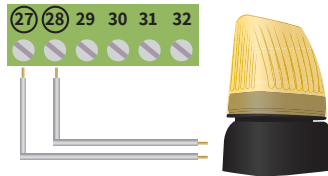

• Without intermittence circuit board



! If you plan to use the photocells test, or a 24V light, this connection cannot be used.

2.4 PRE-LIGHTING

It is possible to increase and reduce the pre-lighting time in case the gate is open or closed, use the function T05 and T06 as shown.



PRE-LIGHTING TIME WHEN THE GATES IS CLOSED.
From 0 to 10 s
Standard value 2 s



PRE-LIGHTING TIME IN CASE THE GATE IS OPEN
From 0 to 10 s
Standard value 2 s

2.5 CONNECTION OF A 24V LIGHT FOR OPEN OR MOVING GATE

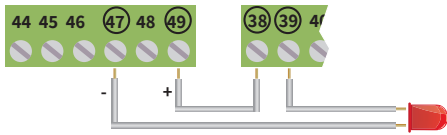

! If you plan to use the photocells test, or a 24V light, this connection cannot be used.

2.6 CONNECTION OF THE LSO AND LSC

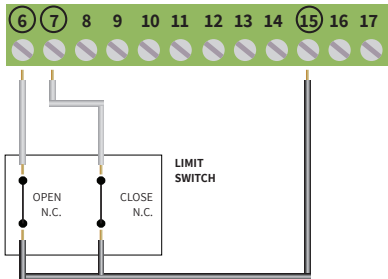

You can see the connection of both limit switches, in this control unit they can be connected separately. So you can use only the LSO or LSC.

! If the LSO or LSC are not used, bring S13, S14 on "0"

S	13	Input LSO
		1 - Activated
		0 - Not activated

S	14	Input LSC
		1 - Activated
		0 - Not activated

2.7 POWER SUPPLY FOR ACCESSORIES

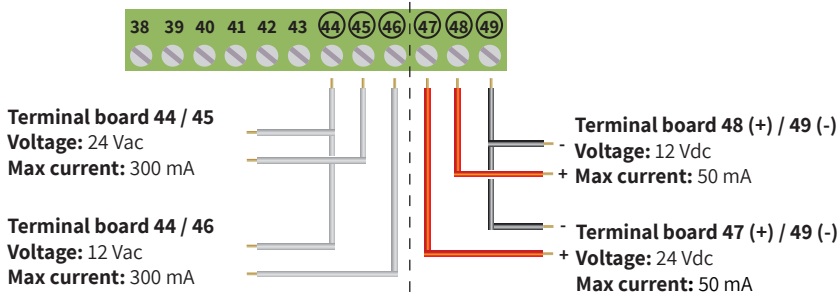

2.8 CONNECTION OF STOP DEVICES

Connection of the STOP control

BUTTON: it stops temporary the control unit until a new command.

SWITCH: the automation stops until a new reset

The connection of safety devices can be done with every button Or a NC contact. If more devices are available they can be serial connected

! If the input STOP is not connected bring S15 into 0

S 15 Input STOP
1 - Activated
0 - Deactivated

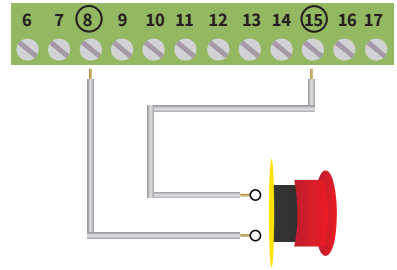

2.9 CONNECTION OF THE START COMMAND

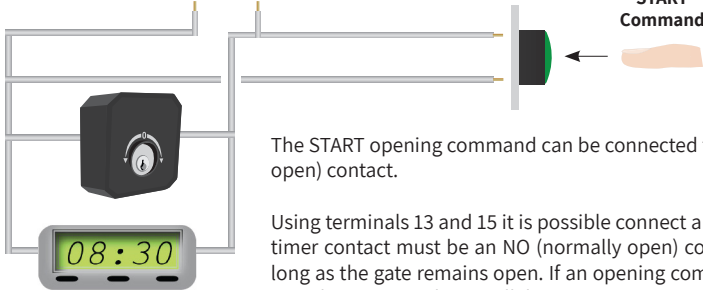

The START opening command can be connected to any push-button or N.O. (normally open) contact.

Using terminals 13 and 15 it is possible connect a TIMER to program gate opening. The timer contact must be an NO (normally open) contact and must remain closed for as long as the gate remains open. If an opening command is connected to terminal 13, it must be connected in parallel.

2.10 CONNECTION OF A PARTIAL OPENING

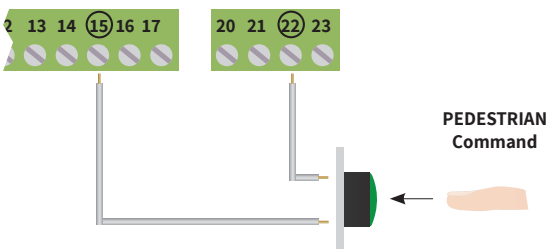

The START opening command can be connected to any push-button or N.O. (normally open) contact.

2.11 CONNECTION OF THE ANTENNA

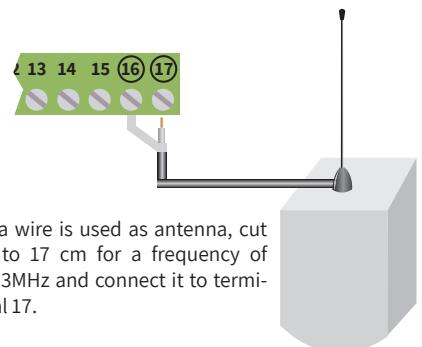

If a wire is used as antenna, cut it to 17 cm for a frequency of 433MHz and connect it to terminal 17.

2.12 CONNECTION OF THE PHOTOCELLS (ONLY CLOSE) 24 VAC

Without TEST

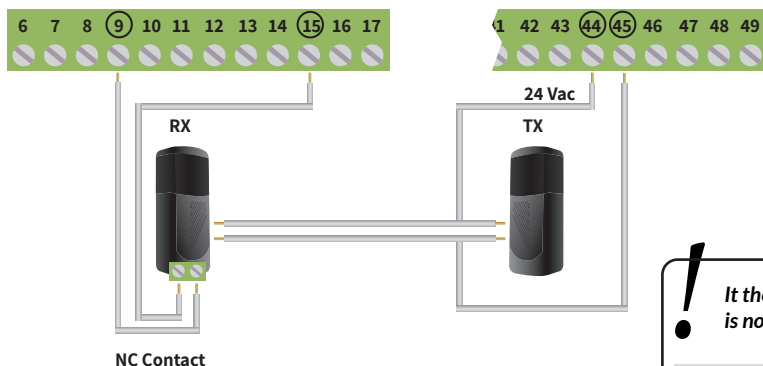

The photocell receiver contact must be:
 - dry (insulated from power supply voltages)
 - type N.C. (Normally closed)

If more than one pair of photo-cells is used, they must be connected in series.

! *It the input PHOTO is not used, put S16 in 0*

S 16	Input FOTO 1 - Activated 0 - Deactivated
------	--

With TEST

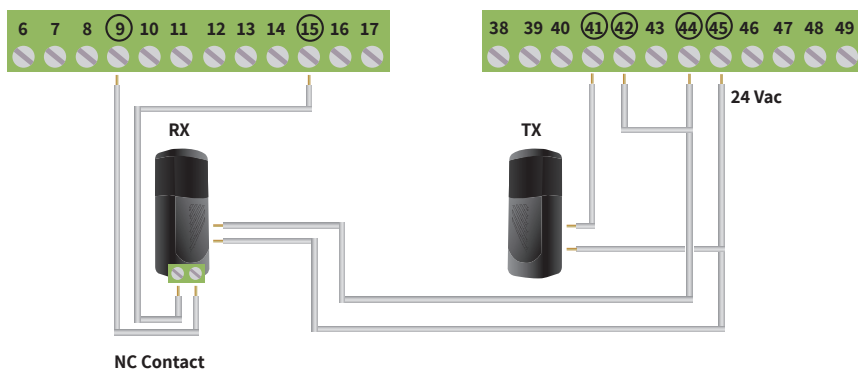

The TEST of the photo-beam works only if the photo-beams are installed properly. The control unit will check all connections before opening!

In case the photo-beam are not working properly the control unit will lit on for 5 seconds and the gate is not working.

To activate the TEST put 1 in the PHOTO-A:

S 09	TEST IN PHOTO-A 1 - Activated 0 - Deactivated
------	---

S 06	TEST IN THE INPUT OF THE SAFETIES 1 - Activated 0 - Deactivated
------	---

If you want to go back to the function WITHOUT TEST, connect the photo-cells And bring 0 to the set up S06 and S09 (deactivate this function only in case other inputs are under TEST).

2.13 CONNECTION OF THE SECURITY OR ANTI-FOLD UP

In case the control units is installed in rapid-rise-doors is possible to connect photobeam for unfolding the curtain. In case the intervention of safeties, the doors stops and reverse the cycle of 1.5sec.

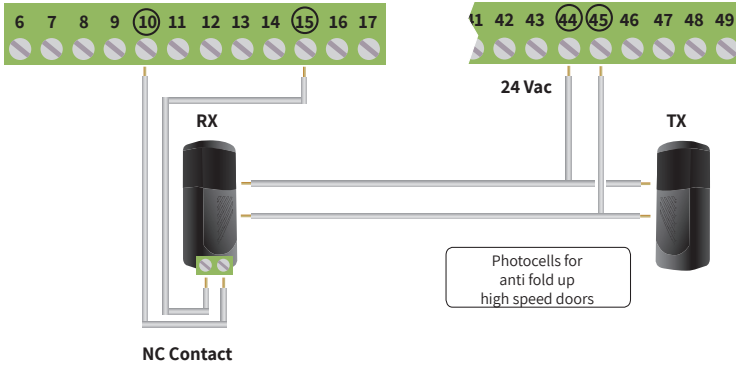

The connection of more safety devices can be done with each button or a N.C. contact. More safety devices should be connected in serial.

! If the input is not used, set S17 at 0

S	17	INPUT UNFOLDING
		1 - Activated
		0 - Deactivated

2.14 OPENING / CLOSING IN CASE OF EMERGENCY

We add this function for START-S19XL for emergency open and close even in case of test for installation. Pay attention that the control unit will exclude the securities (photocells, barriers, limit switches etc)

To open or to close press and keep pressed the button STOP and then keep pressed for at least 5 seconds the button OPEN and CLOSE connected to the terminals 11 and 12.

S	40	→	1	Emergency manoeuvring Activated
		→	0	Emergency manoeuvring Deactivated (Default)

To avoid abnormal openings problems, follow either of the connections:

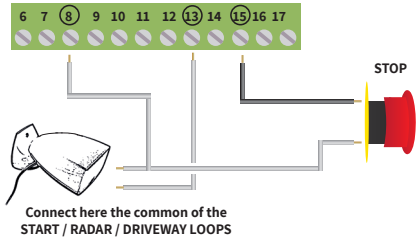

3. USE AND FUNCTIONS OF THE CONTROL PANEL

START-S19XL has a display for a simple and fast programming. The menu has been designed for a clear and fast set up of the working time and the logic of the control unit. You can set up the control unit only when the door is closed.

3.1 SETTINGS AND PARAMETERS

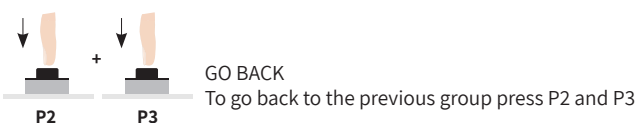
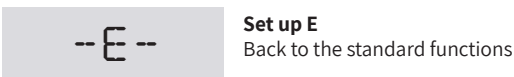
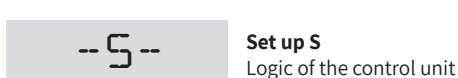
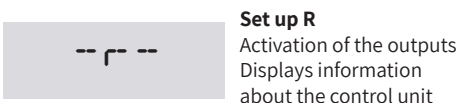
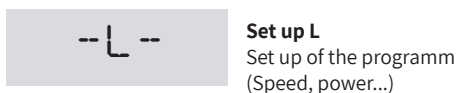
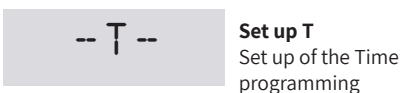
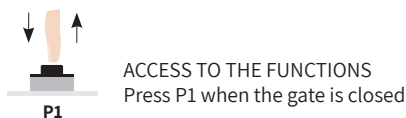

AUTORESET

If the control unit is not used for more than one minute, the control unit go out from the programming saving programs and all changes.

3.2 EXAMPLE HOW TO USE THE MENU AND INFORMATION

It is possible to display some information regarding the condition and the correct operating system of the control panel for example the manoeuvres counter, the resistance value in the input SAFETY EDGE 2 (terminal 14).

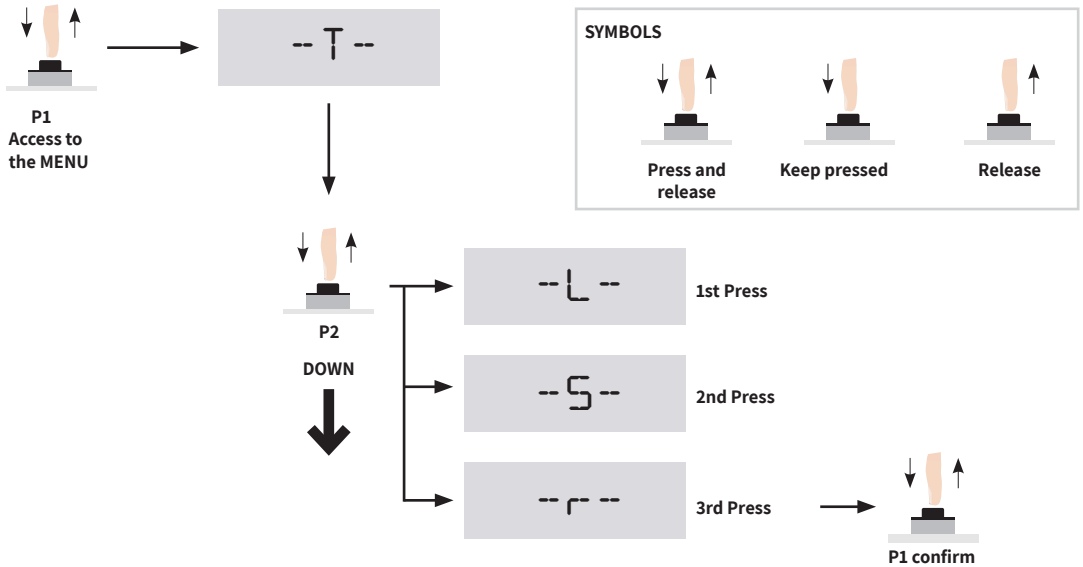

If you confirm with P1 the group R, we enter in the functions: first you choose with buttons P2 and P3 and then confirm with P1. We turn back to R10, R1

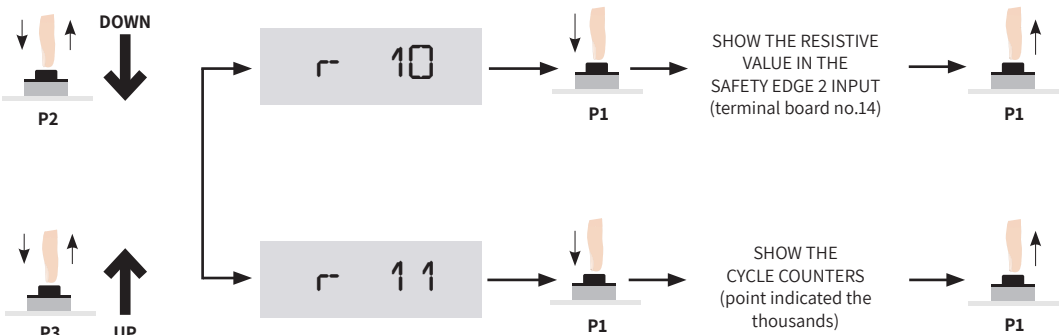

3.3 SET UP A PASSWORD FOR PROGRAMMING

To save all changes it is possible to select a password of 4 numbers. To activate this function make as follow:

- PASSWORD ACTIVATION:**

Press P1, P2 and P3 in the function S32 and then confirm with P1

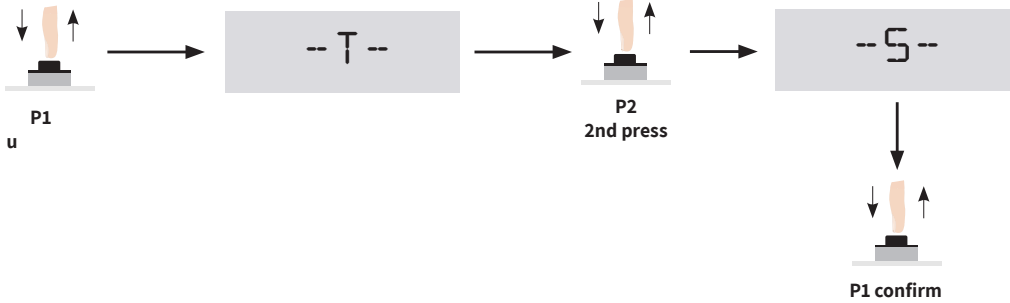

In the function S if you press P1, you can choose the group function: first select P2, now you can go to the function S32 and then confirm with P1.

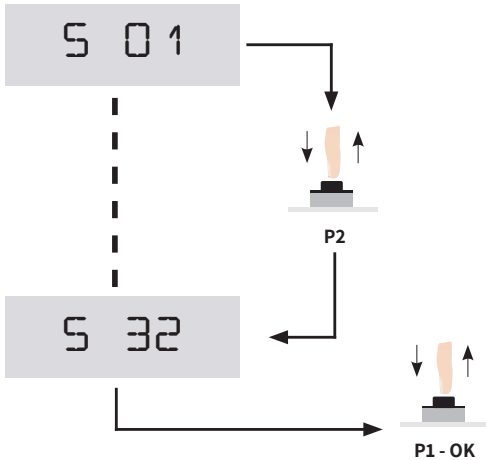

- INSERT PASSWORD**

Choose the first number with the buttons P2 and P3 then confirm with P1. The same procedure applies to the other digits.



Finished entering the 4 digit. Press P1 to confirm. To cancel press P1, within 10 seconds. Otherwise, the next access will be required the security code.

! Pay attention in case you forget the password it is not possible to enter in control board as well.

- DEACTIVATION OF THE PASSWORD**



If you select the function no. S33 you can cancel the password. Wait 10 seconds to confirm the operation.

4. ACTIVATE THE SINGLE OUTPUTS

START-S19XL can open and close separately and the outputs for lamps and test. This is useful in case you want to check the single outputs.

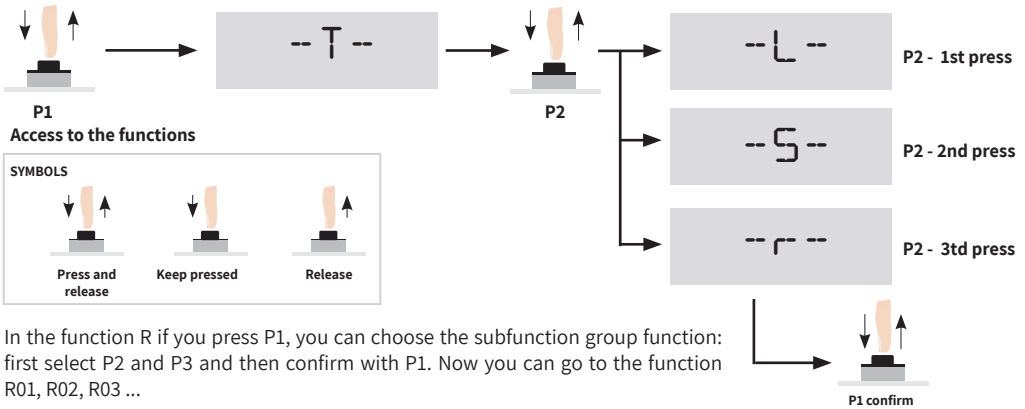

In the function R if you press P1, you can choose the subfunction group function: first select P2 and P3 and then confirm with P1. Now you can go to the function R01, R02, R03 ...

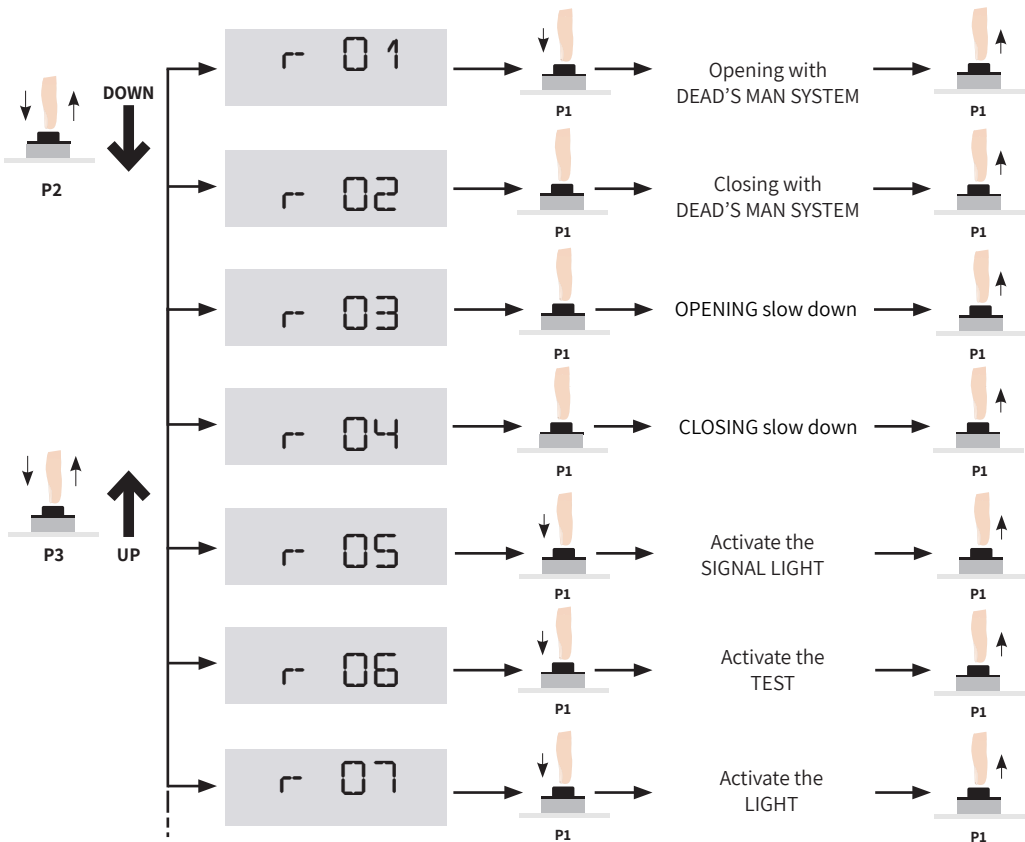

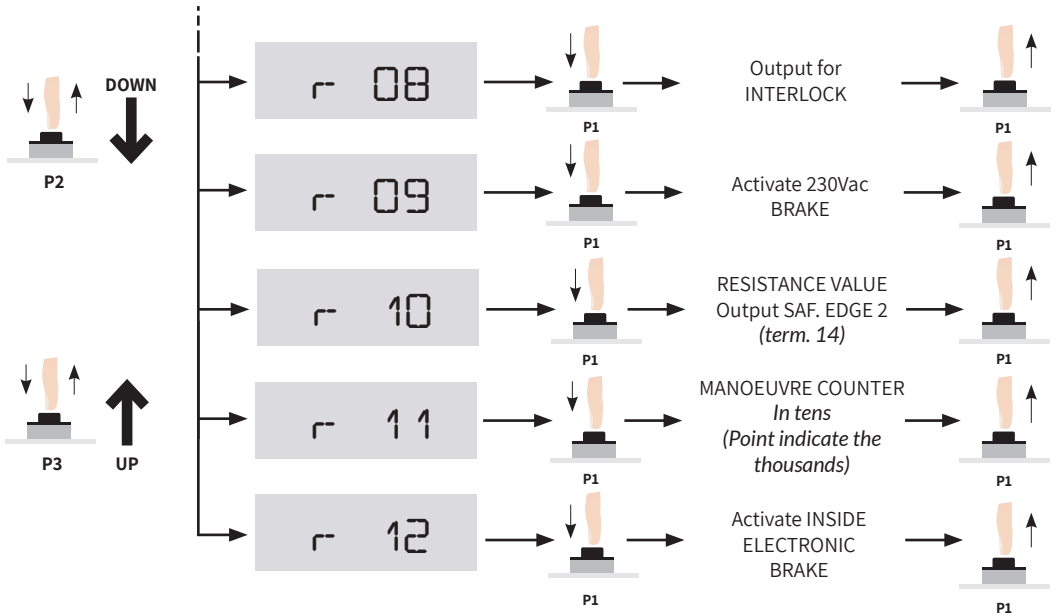

5. FUNCTIONS AND ADJUSTMENT

5.1 LOGIC OF FUNCTIONS

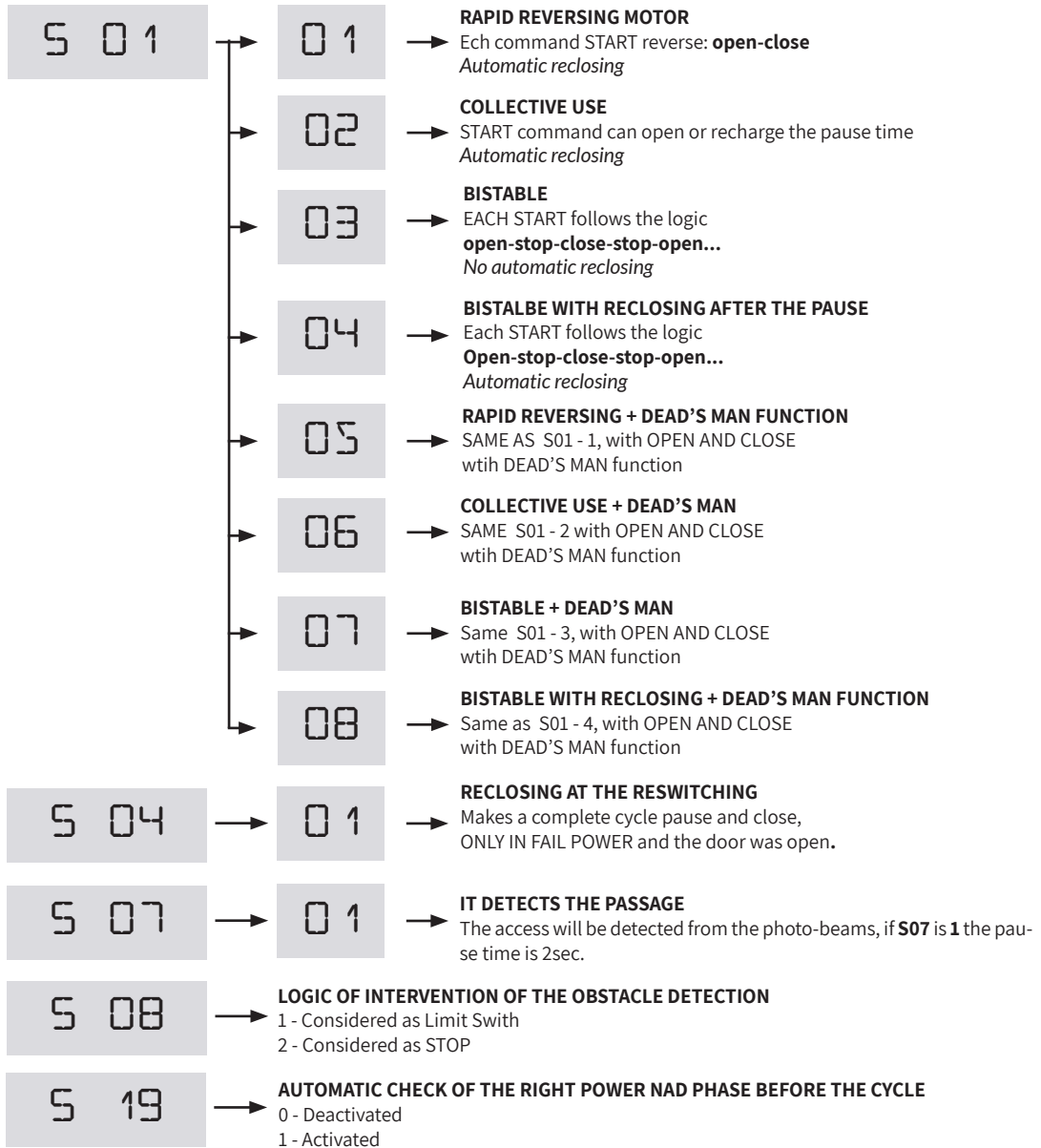

5.2 FUNCTIONS AND ADJUSTMENT

In the following pictures we specify the T functions:

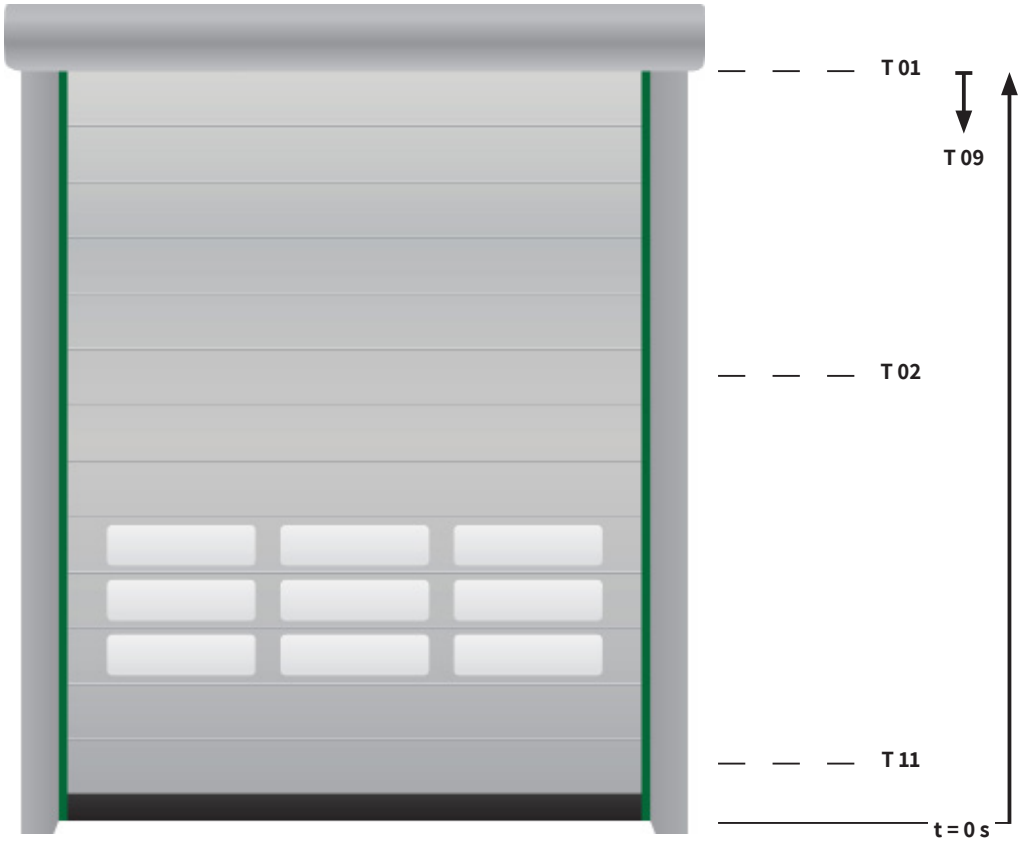

SET UP	DESCRIPTION		DEFAULT - seconds -
T 01	Set up the fully opening time of the door/gate	step da 0,1 s	4,0
T 02	Set up the opening time of partial opening	step da 0,1 s	3,0
T 03	Pause time for START or OPEN	step da 0,1 s	2,0
T 04	Pause time for PARTIAL OPENING	step da 0,1 s	1,0
T 08	Set up start position of deactivation of the photocelle. It is not considered if S03 is set in 1	step da 0,1 s	0,5
T 09	Deactivation Time of the input SAFETY EDGE (term.10) from starting of LSO. <i>This function is useful in case of anti-folding to avoid the unroll of the curtain which can temporary cover the photocell and the door will start opening again.</i>		1,0

5.3 SET UP OF SPEED AND ACCELERATION

Here are reported the parameters for SPEED, ACCELERATION and CONSUPTIONS:

Setup	Description
L 01	Set up of the SOFT START. At 0 the function is not activated From 1 to 10 will increase the speed of the starting point
L 02	Not used
L 03	Level for the automatic stop for the current of the motor.
L 04	Persisting time for the consumption of the motor Increase this value to increase the intervention of the motor stop.

With L1 with values from 1 to 10 (0 is not activated) is possible to start the motor with a starting point. The more is this value high, the more this value is high the more the engine torque is larger.

Parameters L3 and L4 are the level of the intervention for the absorption of the consumption of the motor and the intervention time L3 lo can be tested using TEST of motor R01 and R02 when it will be displayed the value for the consumption of the motor.

5.4 CONNECTION OF RX RADIO BAND WITH MOLEX (AVAILABLE ON REQUEST)

It is possible to connect the receiver of the radio band with a MOLEX Connector. If you need to learn the transmitters read the operating guide. Set up pin strip JP1 - JP2 - JP3 as shown, according to the installation.



Here is the TEST of the Radio System RX

JP3 JP2

The output for the RX Radio System are 54-55-56. To avoid the wiring connection of the output OUT1 with input COSTA 2 (safety edge 2) is possible to set up the JP1 as shown,









OUT1 output (terminal 54) is connected to the input COSTA 2 (terminal 14) without wiring.

JP1

5.6 MEMORIZATION OF THE ENCODER KOSTAL

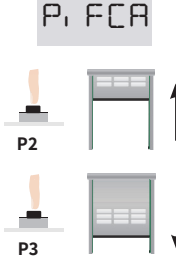
Once you terminate the connections:

1	Set S 41 to 1 for activated the Kostal encoder (2000 version)	
2	Deactivate all LS inputs with parameters S13, S14. Bring all at 0.	
3	With R03 and R04 check the direction of rotation of the motor and positionate the door at around 10 cm over the position of the LSC.	
4	Bring to parameter R13, press P1 to learn the position of the door.	
5	<p>The display shows P.FCA which indicate the LSO. Use buttons P2 (doors OPEN) and P3 (door CLOSES) positionate the door where it need to stop when opening, then confirm with P1.</p> <p><i>Warning ! When the door is opening or closing the sial shows the position detected by the encoder. If the value is opposed to the direction (opening increase and closing reduce, you need to change the parameter S39.</i></p>	
6	Now starts the countdown at 10 seconds, if you need cancel the operation press P1 (in this seconds) otherwise wait for the end of the operation.	
7	Exit from the settings, give a START or OPEN command and wait the door closes. (This processing deactivate the input PHOTO A (S 16), in case you need , activate it manually.	
8	Using parameter T14 for the adjustment of the position of the LSC. The neutral value is 100, increase this valule (Max 200) if you need to go over this position, reduce T14 (Min 0) if you need the door wait before the selected position.	

6. RESTORE OF FACTORY DEFAULT SETTINGS

The control panel reset to the Standard values, and it can remind the parameters programmed from the user.

6.1 RESTORE FACTORY SETTINGS

Checking those parameter of the parameters, you can look the set up during the RESET of the control unit. Select the paragraph S18 as shown.

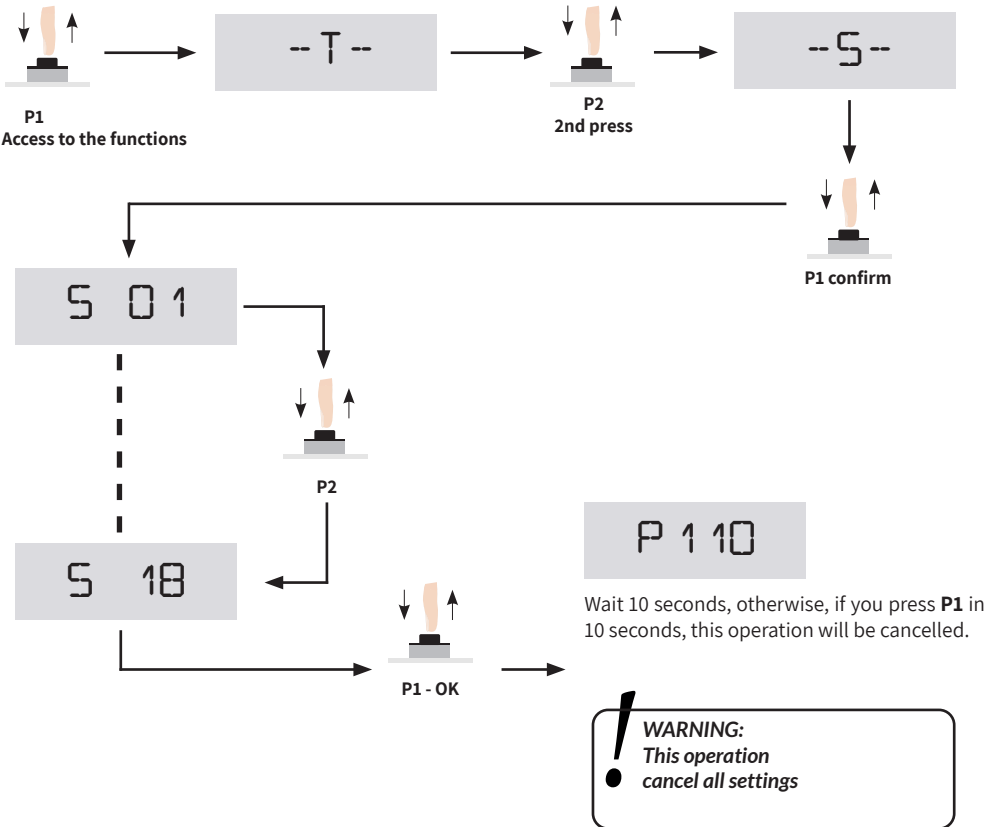

For standard values see table at pag no. 21 and following.

6.1 SAVE AND CHECK OF THE PARAMETERS

START-S19 has 2 memory slots saving all manually set up and you can check it again. See how to check the set up with functions **S23**, **S24**, **S25**, **S26**. Once all parameters are set up, it is possible to change.

Thanks of the 2 memory slots, it is possible to save and check 2 differents set up.

• MEMORY 1 (slot 1)

S 23 *Press P1*
Save settings
Memory 1

S 25 *Press P1*
Charge settings
memory 1

• MEMORY 2 (slot 2)

S 24 *Press P1*
Save settings
Memory 2

S 26 *Press P1*
Charge settings
memory 2

7. TROUBLESHOOTING

Here are listed all main problems indicated in the display, you can see the possible causes and the solutions.

Problem	Description
Er 01	Overcoming of the security concerning the motor absorption.
Er 02	Possible damaged of the power check.
Er 03	Error in the networ synchronisation
Er 04	Fail Phases. <i>We recommend to check F3</i>
Er 05	Password not correct <i>Try again.</i>
Er 17	ENCODER position error press the OPEN and CLOSE buttons in the dead man to reposition the door

8. INSTALLATION

8.1 GROUP S

	DESCRIPTION	
S 01	Logic of the control unit 1 - Rapid reversing 2 - Collective use 3 - BISTABLE 4 - Bistable with automatic reclosing 5 - Rapid Reversing + dead's man 6 - Collective use + dead's man 7 - Bistable + dead's man 8 - Bistable with automatic reclosing+ dead's man	from 1 to 8
S 02	Activation complete cycle open and close by power fail if the gate/door was open	0 Off - 1 On
S 03	Inhibiton input FOTO A After intervention of the LSC slowing down	0 deactivate - 1 activate
S 04	Detecting passage	0 Off - 1 On
S 05	Activate the signal light in pause	0 Off - 1 On
S 06	Activation TEST in the inputs with activated TEST	0 Off - 1 On
S 07	Activated the reversing after detecting the passage (S04 = ON)	0 Off - 1 On
S 08	Logic of the intervention of the obstacle detection	1 - Considered as LS 2 - Considered as STOP
S 09	Activate TEST in the PHOTOCCELL input	0 Off - 1 On
S 10	Activate TEST in the input SAFETY EDGE 1	0 Off - 1 On
S 11	Activated TEST in the input STOP	0 Off - 1 On
S 12	Activate flashing in the signal light output	0 Off - 1 On
S 13	Activate input LSO	0 Off - 1 On
S 14	Activate input LSC	0 Off - 1 On
S 15	Activate input STOP	0 Off - 1 On
S 16	Activate input PHOTO	0 Off - 1 On
S 17	Activate input SAFETY EDGE 1	0 Off - 1 On
S 18	RESET at factory's settings	
S 19	Automatic check the right power nad phase before the cycle	0 deactivate - 1 activate
S 20	Activate input Switch slow down OPEN	0 Off - 1 On
S 21	Activate input Switch slow down CLOSE	0 Off - 1 On
S 22	Activate input SAFETY EDGE 2	0 deactivate - 1 activate
S 23	Copy settings in memory 1	
S 24	Copy settings in memory 2	
S 25	Remind settings in memory 1	
S 26	Remind settings in memory 2	

	DESCRIPTION		DEFAULT
S 27	Charge standard settings 1		
S 28	Charge standard settings 2		
S 29	Charge standard settings 3		
S 30	Charge standard settings 4		
S 31	Charge standard settings 5		
S 32	Activate the password to enter in the menu. Inser the code and let the time goes		
S 33	Deactivate the password to enter in the menu		
S 34	Not used		
S 35	Activate interlock function (with S04 in 1 activate the 2nd door after detecting the passage)	0 deactivated - 1 activated	0
S 36	Activate input SAFETY EDGE 1 when opening, too	0 deactivated - 1 activated	0
S 37	LIGHT output, functioning as SIGNAL LIGHT	0 deactivated - 1 activated	0
S 38	Contact safety edge 2	0 contact N.C. - 1 contact 8K2	1
S 39	Reversing the encoder Kostal	0 - 1	
S 40	Opening / Closing in case of emergency	0 deactivated - 1 activated	
S 41	Encoder Kostal	0 deactivated - 1 activated	
S 42	Present Man for the CLOSE command (It is important to set the control unit without automatic reclosing and connect the OPEN input)	0 disattivato - 1 attivato	

8.2 GROUP R

	DESCRIPTION
R 01	Activate opening until release of P1 with acceleration
R 02	Activate closing until release of P1 with acceleration
R 03	Activate opening until release of P1 with slow down speed
R 04	Activate closing until release of P1 with slow down speed
R 05	Activate out SIGNAL LIGHT until release of P1
R 06	Activate output for TEST until release of P1
R 07	Activate output LIGHT until release of P1
R 08	Activate outpu for interlock
R 09	Activate 230 Vac brake
R 10	Value of the input SAFETY EDGE 2
R 11	NUMBER of cycles
R 12	Activate the built-in electronic brake

8.3 GROUP T

	DESCRIPTION
T 01	Time of position LSO
T 02	Time of stop position of the PARTIAL OPENING
T 03	Pause time for START and OPEN Command
T 04	Pause Time for PARTIAL OPENING
T 05	PRE-LIGHTING time when open
T 06	PRE-LIGHTING time when close
T 07	Time to research the LS
T 08	Position end of inhibition of the input PHOTOCCELL
T 09	Inhibition Time input SAFETY EDGE 1 from LSO when closing
T 10	Inhibition time check of the motor absorption from activation
T 11	Pause time in the reverse of the direction
T 12	Delay time of the stop of the motor after detecting LSO
T 13	Delay time of the stop of the motor after detecting LSC
T 14	Adjustment of the limit switch position

8.4 GROUP L

	DESCRIPTION
L 01	Set up of the SOFT START. At 0 the function is not activate. From 1 to 10 will increase the speed of the starting point
L 02	Not used
L 03	Level for the automatic stop for the current of the motor.
L 04	Persisting time for the consumption of the motor Increase this value to increase the intervention of the motor stop.

9. DECLARATION OF CE CONFORMITY

(according to EC Directive 2006/42, Attachment II, part 1, ses. A)

The undersigned **Ernestino Bandera**,
Administrator



DECLARES THAT:

Company: EB TECHNOLOGY SRL
Address: Corso Sempione 172/5
 21052 Busto Arsizio VA Italy
Product's name: START-S19XL
 Control unit for 1 single-and-three
 phase motor up to 2HP

THE PRODUCT COMPLIES with what is outlined in the European Community directive:
2006/42/CE
EC DIRECTIVE 2006/42 ISSUED BY THE EUROPEAN PARLIAMENT AND COUNCIL on may 17, 2006 harmonizing the legislation of the member countries regarding machinery.
Reference: Attachment II, part 1, ses. A (EC Declaration of Conformity issued by the manufacturer).
THE PRODUCT COMPLIES with what is outlined in the European Community directives:
2014/35/EU
DIRECTIVE 2014/35/EU OF THE EUROPEAN PARLIAMENT AND OF THE COUNCIL of 26 February 2014 on the harmonisation of the laws of the Member States relating to the making available on the market of electrical equipment designed for use within certain voltage limits.
Reference to harmonized standards: EN 60335-1
2014/30/EU
DIRECTIVE 2014/30/EU OF THE EUROPEAN PARLIAMENT AND OF THE COUNCIL of 26 February 2014 on the harmonisation of the laws of the Member States relating to electromagnetic compatibility.
Reference to harmonized standards: EN 61000-6-2 EN 61000-6-3
The directive 2006/42/CE remind that it is not allowed the function of the product until the machine, for which the product is included, is not indentify and declared conformed to the 2006/42/CE directive.

Busto Arsizio, April 30th 2020
Administrator
Ernestino Bandera

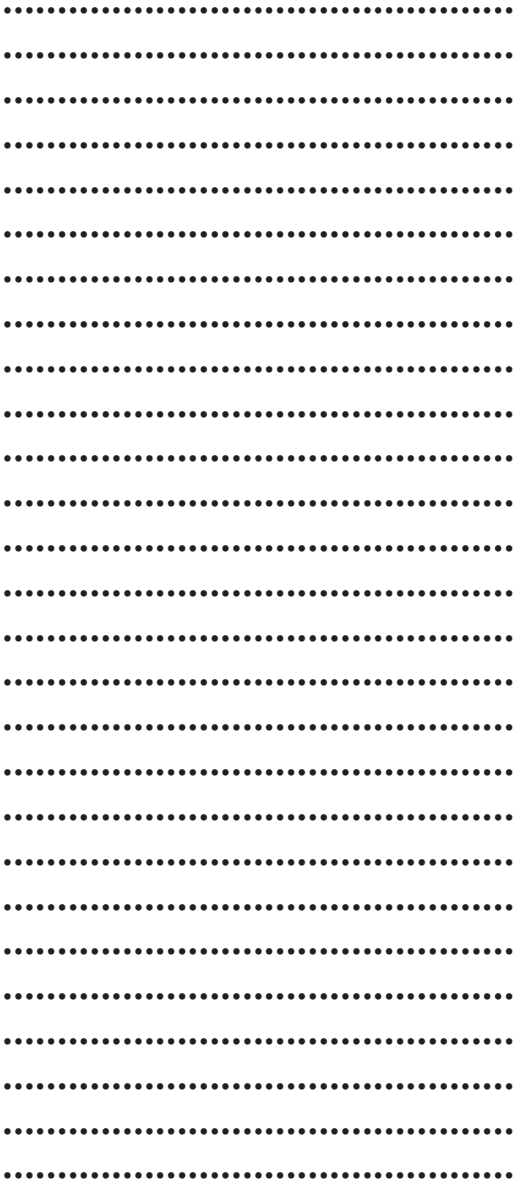

EB TECHNOLOGY S.r.l.
Corso Sempione 172/5,
21052 Busto Arsizio VA Italy

NOLOGO S.r.l.
Via A. Pacinotti, 44
20035 Villa Cortese MI Italy
tel. +39 0331.430457
fax. +39 0331.432496

posta@ebtechnology.it
www.ebtechnology.it

info@nologo.info
www.nologo.info

