

# DC Variable-Frequency Barrier Gate

DZ04VF (DC24V)

Manual

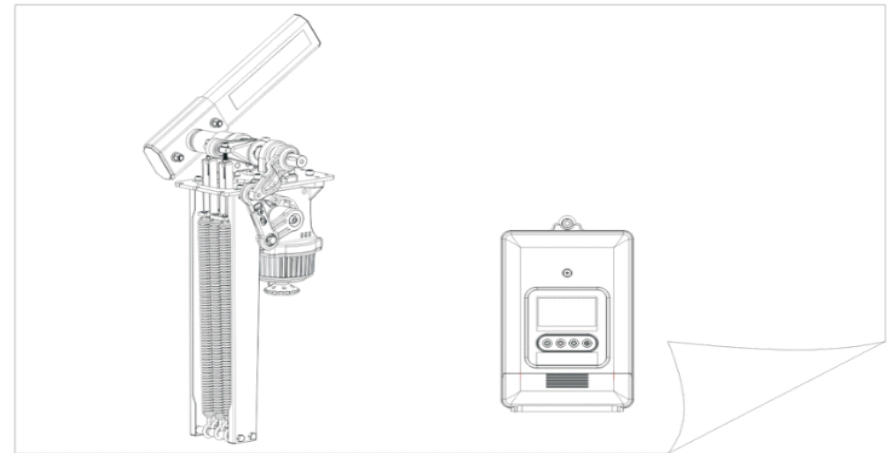





V1.0.2

## Preface

### Symbol Stipulations

The meanings of the following symbols which may appear in this manual

Symbols	Meanings
 <b>Danger</b>	Indicates that there is a high level of potential danger, if not avoided, it may cause casualties or serious injuries.
 <b>Warning</b>	Indicates that there is a medium or low level of potential danger. If not avoided, it may cause minor or moderate injury to personnel.
 <b>Attention</b>	Indicates potential risks. If you ignore the information, it may cause equipment damage, data loss, equipment performance degradation, or unpredictable results.
 <b>Tips</b>	Indicates that it can help you solve a problem or save your time.
 <b>Note</b>	Indicates that it is the additional information of the main text, which emphasizes and supplements the main text.

### Revision Records

Version No.	Revision Content	Release Date
V1.0.0	First Release	2021.07
V.1.0.1	Adding “3.5.2 Quick Adjustment Instruction”	2021.09
V.1.0.2	Change photo of mechanism, modify “4. 5. 8. Valid time of loop detector signal”	2022.03

### Safety Instructions

The following is the correct methods of using the product, in order to prevent danger, prevent property damage, etc., please read this manual carefully before using the equipment and strictly follow it during use. Please keep the manual properly after reading.

#### Operating Environment Requirements

Please transport, use and store the device within the allowable humidity and temperature range. Please do not let any liquid flow into the device.

Please install the device in a well-ventilated place, and do not block the vents of the device.

Please do not press hard, vibrate violently or soak the equipment.

Please use the factory packaging or materials of the same quality when shipping the equipment.

It is recommended to ground via the grounding hole on the device to improve the reliability.

#### Operation and Maintenance Requirements

Please do not disassemble the device privately.



Please use the accessories or attachments of the manufacturer for installation and maintenance by professional service personnel.

Please do not provide two or more power supply methods to the device at the same time, otherwise the device may be damaged.

The self-contained boom is not allowed to be lengthened or cut off, and it is also not allowed to add weight to the boom privately.

## Contents

Preface.....	I
Safety Instructions.....	I
1. Production Overview.....	1
1.1. Functions and Features.....	1
1.2. Technical Data.....	1
2. Product Structure.....	1
2.1. Mechanism Structure.....	1
2.2. Installation Direction Definition.....	2
3. Mechanical Part Installation and Adjustment.....	3
3.1. Cabinet Installation.....	3
3.2. Boom Installation.....	3
3.3. Spring Installation and Adjustment.....	5
3.4. Change Mechanism Installation Direction .....	6
4. Controller Explanations and Instructions.....	7
4.1. Controller Interface Explanations.....	8
4.2. Quick Adjustment Instruction .....	9
4.3. Controller Parameter Setting.....	10
4.4. “Regular Menu” Command List.....	10
4.5. “Advanced Menu” Command List.....	14
5. Common Malfunctions and Solutions.....	18
6. Warranty and Service Items.....	19
7. Maintenance.....	19
8. Packing List.....	20
9. Spring Selection Table.....	21

## 1. Production Overview

### 1.1. Functions and Features

1.1.1. DC variable frequency control motor drive, equipped with connecting rod transmission mechanism, balance spring, stable and reliable operation, motor life up to 4.5 million times, spring life 500,000 times.

1.1.2. Auto reversing on obstacle function, the boom will auto reverse when it meets obstacle during the closing process.

1.1.3. Support external radar, coil, infrared anti-smashing function, built-in DC 12V power output, can be used for external radar power supply.

1.1.4. Support RS485 communication or RS485 off-line connection.

1.1.5. Optional Bluetooth module, convenient debugging of barriers through small programs.

1.1.6. Large LCD screen display, English visual menu, easy function selection and debugging.

1.1.7. Left-installation and right-installation can be changed.

1.1.8. Speed 1.5~6 seconds can be adjusted.

### 1.2. Technical Data

1.2.1. Working temperature (motor):  $-35^{\circ}\text{C} \sim +70^{\circ}\text{C}$

1.2.2. Power supply input voltage: AC110~265V

1.2.3. Controller input voltage:  $\text{DC}24\text{V} \pm 10\%$ , 10A

1.2.4. Motor power: 240W MAX

1.2.5. Relative Humidity: 30%~80%, No condensation

1.2.6. Distance of remote control:  $L \geq 30\text{M}$

## 2. Product Structure

### 2.1. Mechanism Structure

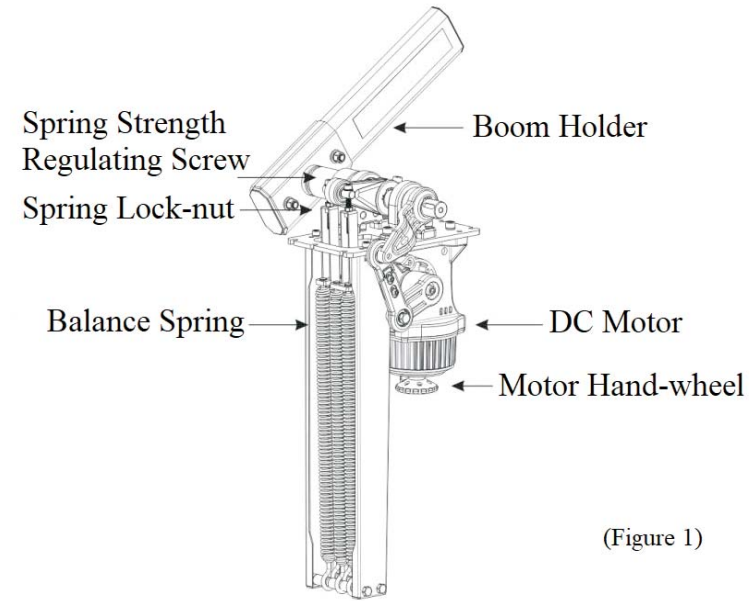

(Figure 1)

### 2.2. Installation Direction Definition

When placing the order, please confirm “left-installed” or “right-installed”. Figures as below:

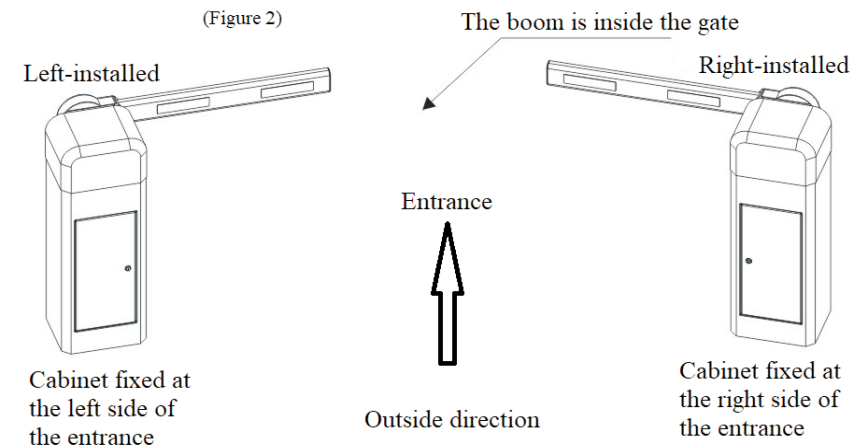

(Figure 2)

### 3. Mechanical Part Installation and Adjustment

#### 3.1. Cabinet Installation

According to the specific conditions of the site, select the barrier gate of the appropriate specification, and use the expansion bolts to fix the cabinet on the ground with the size shown in the figure below. At the location where the cabinet is installed, the barrier foundation should be made according to the site conditions, and the cast-in-place foundation should be made for the non-concrete ground.

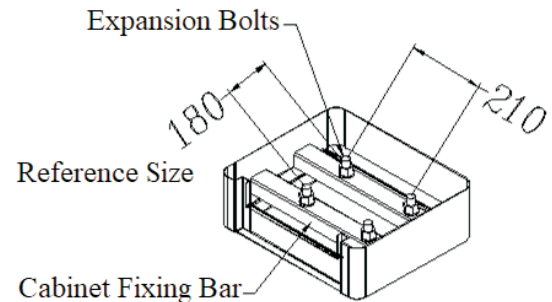

(Figure 3)

(according to the supplementary size)

#### 3.2. Boom Installation

##### Note

Installation Pictures for reference only, the product prevails in kind.

##### 3.2.1 Straight boom installation

**Step 1.** Fix the boom holder press board on boom with 2pcs of M12\*70mm hexagon screw.

**Step 2.** Press the board by hand, then lift up the boom vertically and install it on the boom holder.

**Step 3.** Install the flat washer, spring washer, and M12 nut on the screw in turn, and fix the screw with a wrench.

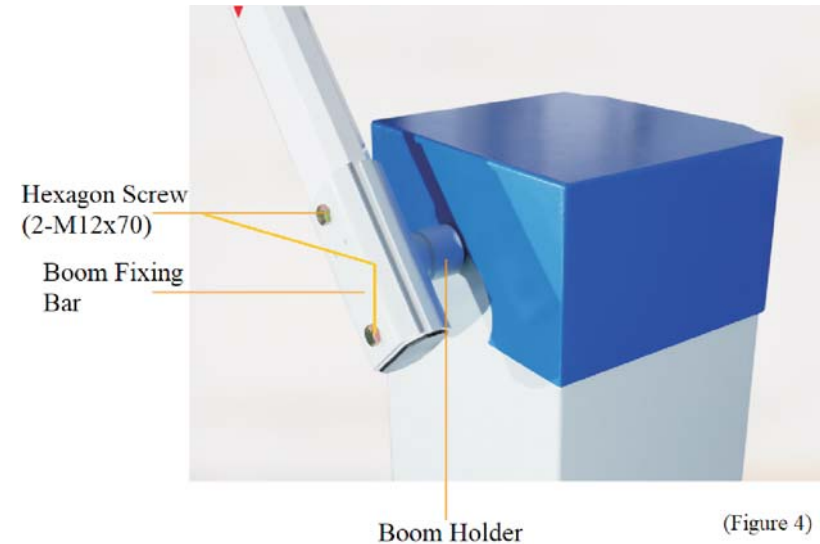

(Figure 4)

##### 3.2.2. Folding boom installation

**Step 1.** Fix the boom holder press board on boom with 2pcs of M12\*70mm hexagon screw.

**Step 2.** Step 2. Press the board by hand, then lift up the boom vertically and install it on the boom holder. Install the flat washer, spring washer, and M12 nut on the screw in turn, and fix the screw with a wrench.

**Step 3.** Fix the bearing of the connecting unit to the cone axis on barrier with screw.

**Step 4.** Fix the bottom fence to the connecting unit, then release the 2pcs screw of the unit and adjust them to make the fence be perpendicular to the ground.

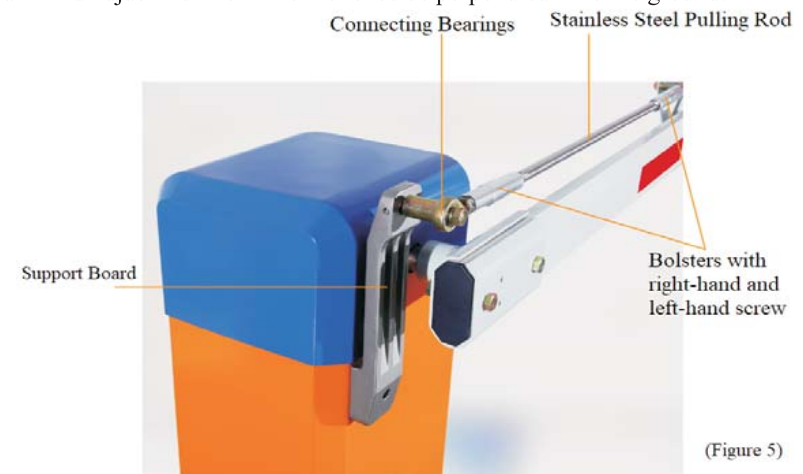

(Figure 5)

### 3.2.3 Fence boom installation

**Step 1.** Fix the boom holder press board on boom with 2pcs of M12\*70mm hexagon screw.

**Step 2.** Press the board by hand, then lift up the boom vertically and install it on the boom holder. Install the flat washer, spring washer, and M12 nut on the screw in turn, and fix the screw with a wrench.

**Step 3.** Fix the bearing of the connecting unit to the cone axis on barrier with screw.

**Step 4.** Fix the bottom fence to the connecting unit, then release the 2pcs screw of the unit and adjust them to make the fence be perpendicular to the ground.

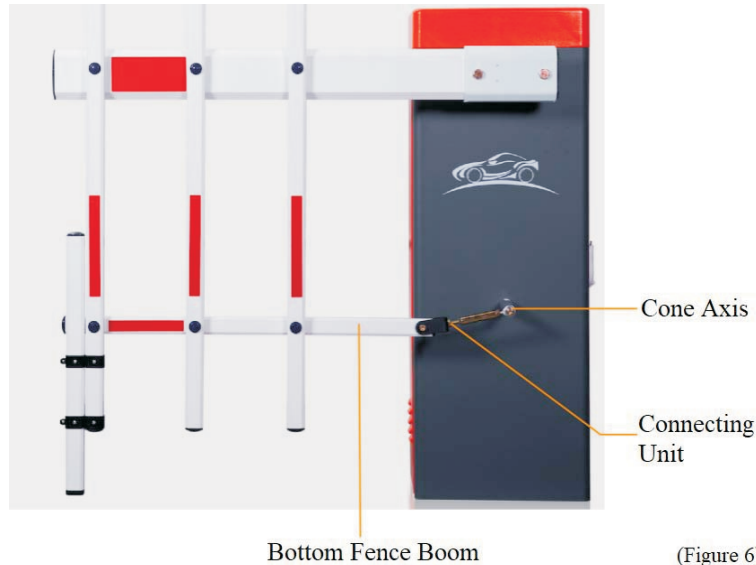

(Figure 6)

### 3.3. Spring Installation and Adjustment

#### Note

The barrier gate is well adjusted before delivery. Please do not change boom type and boom length at will. The length of springs prevails in kind, designing change without notice. Periodic maintenance of springs is required due to its wear-tear feature.

**Step 1.** Spring installation, dis-assembly and replacement

Keep the boom at vertical position, loosen the spring fastening nuts, unscrew the M8x140mm spring adjusting screws by a hexagonal spanner, then take off the spring. The steps for installation and disassemble the spring are the opposite.

**Step 2.** Spring force adjustment

When power off, please turn the motor hand wheel to make the boom move towards

the closing direction, when the boom gets close to the horizontal position, if the hand wheel can not be turned smoothly, which means that the spring force is small, users need to tighten the spring; and then please turn the motor hand wheel to make the boom move towards the opening direction, when the boom gets close to the vertical position, if the hand wheel can not be turned smoothly, which means that the spring force is big, users need to loose the spring. Repeat the below operations and adjustment until the hand wheel can be turned smoothly, which mean the spring force is at balance status.

#### Note

Judging spring force by observing boom running situation also works. If boom shaking when opening, spring force is too strong. If boom shaking when closing, spring force is too low.

### 3.4. Mechanism Installation Direction Change

This barrier mechanism can be both left-installed and right-installed. The users can change the installation direction according to the actual situation. We will take the left-installed barrier mechanism as an example, and the operation steps for changing to the right-installed are as follows:

Take out the 10MM screw by turning 8MM Allen wrench counterclockwise

Push out the boom holder by turning wrench clockwise with a 14MM\* 150 screw

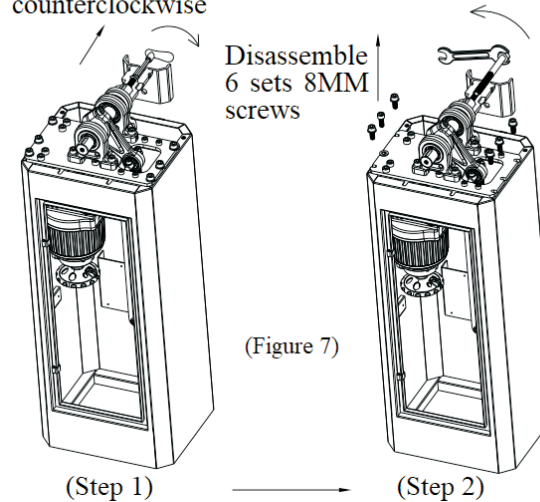

(Figure 7)

Turn the mechanism 180 degrees vertically

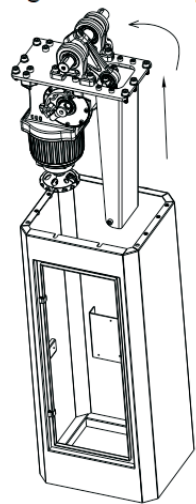

(Step 3)

Put the mechanism into the cabinet

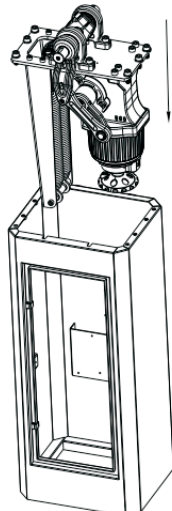

(Step 4)

Assemble the boom holder back, and fix the 10MM screw by turning 8MM Allen wrench clockwise

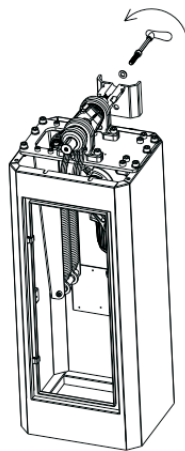

(Step 5)

(Figure 8)

#### 4. Controller Explanations and Instructions

##### Note

All the electrical connections are done before delivery. The necessity is to connect the power and grounding connection.

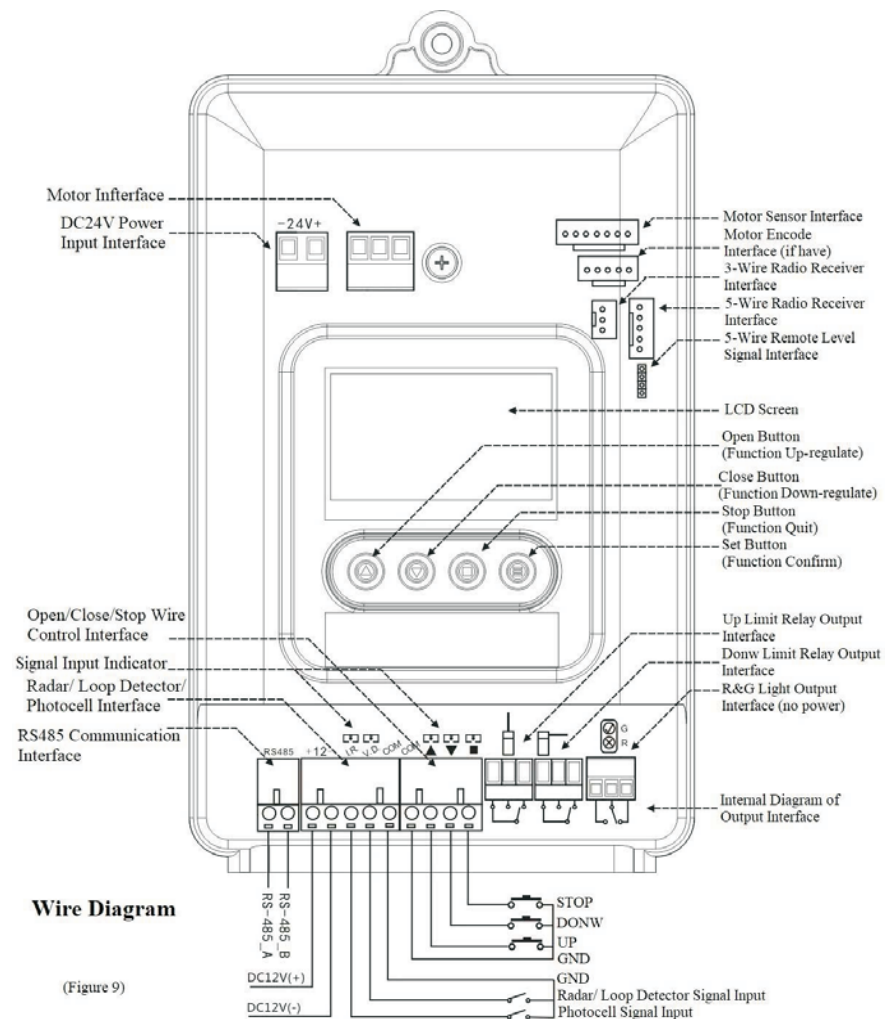

(Figure 9)

#### 4.1. Controller Interface Explanations

Item	Explanation
Wire Control Interface	This interface is available for parking system, also available for external controller to control barrier gate. UP: Short circuit "UP" and "GND" Down: Short circuit "Down" and "GND" Stop: Short circuit "Stop" and "GND"

Item	Explanation
Anti-smashing Interface	Infrared Photocell: boom will lift up when short circuiting "Infrared photocell interface" and "GND" during boom down. Loop Detector: boom will lift up when short circuiting "loop detector interface" and "GND" during boom down; in up limit position, boom will fall down automatically after these two interfaces disconnected.
RS485 communication interface	It is used for controlling the barrier gate or checking the status of the barrier gate by computer or system; also used for online controlling the paired barrier gates synchronously.
Limit Relay Output Interface	It is used for the system to checking the status of the barrier gate by the opening and closing times; users can also change to other output modes via option 4 of the advanced menu.
DC12V Power Output	Provide 1A current output, available for radar or small light strips.
Interface for R&G lights	Available to connect with R&G lights, to indicate the working status of the barrier gate.
Function Buttons	The 4 buttons have two working status: normal working status and menu setting status, the function of normal working status is that "▲" is the opening function, "▼" is the closing function, "■" is the stopping function, "≡" is the setting function which is invalid when it is short pressed under normal working status; Long press "≡" for 2 seconds to enter the menu setting status. In the menu setting status, "▲" and "▼" are used to adjust menu items or parameters, "■" is to cancel the set value or exit the menu setting status, "≡" is used to enter the next menu or save the set value.
LCD Screen	It is used to display the information of the barrier gate such as the working status, parameters, menu items.

## 4.2. Quick Adjustment Instruction

This barrier gate was well adjusted according to the order requirements before delivery. If there is any change in the boom length, or spring, or the control board, the barrier gate can be adjusted quickly according to the following steps in the operating environment without roofs.

Step	Name	Operation	Remarks
1	Choose DZ04VF	Long press button "≡" for	Speed choice: 6M/5S means

	from the menu "3. Quick Operation Parameter"	3s to enter setting status, then enter the "3. Quick Operation Parameter" to choose "DZ04VF"	6m boom opening or closing in 5s
2	Open and close many times to check if boom runs stably	Press the push button on the remote controller to open and close the barrier gate	If boom too long, it is normal if it shakes at the first time to learn the horizontal and vertical limit position.
3	Boom shakes during running	Well adjust the parameters of 4.4.1 and 4.4.2 in the regular menu	Refer to "5. Common Malfunctions and Solutions" on page 18
4	Adjust the horizontal limit position	After entering the menu, enter to regular menu "4.4.4. Position Setting" to adjust it to the value "4.5 Horizontal Fine Adjustment"	Refer to page 13

## 4.3. Controller Parameter Setting

Long press "≡" button for 2 seconds to enter the regular menu setting status. Select menu items by short press or long press "▲" and "▼" buttons, short press once to increase or decrease by one, long press to continuously increase or decrease. When the required diameter displayed by the LCD, press "≡" button again to enter the setting of the specified item, and press the "■" to return to the previous level or exit the setting. When the specified parameter setting is completed, you must press "≡" button to confirm it to take effect. The currently set parameters is invalid if pressing "■" button.

## 4.4. "Regular Menu" Command List

### 4.4.1. Opening operation parameters

Sub-menu	Defaults	Range	Remarks
1.1 Acceleration Time	8	1-20	The smaller the value, the faster the speed
1.2 Opening Speed	40	15-100	The bigger the value, the faster the opening speed
1.3 Deceleration Angle	60	10-80	The angle at which deceleration begins in the opening process; if the

			boom shakes after it is opened in place, users can reduce this value.
1.4 Angle of Low-speed Area	90	45-90	The angle at which the boom enters a low-speed area in the opening process; if the boom shakes after it is opened in place, users can reduce this value.
1.5 End Speed	8	1-50	The minimum speed at which the barrier gate is opened in place; if the boom shakes after it is opened in place, users can reduce this value.
1.6 Learning Speed	25	10-50	The speed at which the the barrier gate begins to learn the up limit position after the power is turned on for the first time.

#### 4.4.2. Closing operation parameters

Sub-menu	Defaults	Range	Remarks
2.1 Acceleration Time	8	1-20	The smaller the value, the faster the speed
2.2 Closing Speed	40	15-100	The bigger the value, the faster the opening speed
2.3 Deceleration Angle	40	10-80	The angle at which deceleration begins in the closing process; if the boom shakes after it is closed in place, users can increase this value.
2.4 Angle of Low-speed Area	0	0-45	The angle at which the boom enters a low-speed area in the closing process; if the boom shakes after it is closed in place, users can reduce this value.
2.5 End Speed	4	1-50	The minimum speed at which the barrier gate is closed in place; if the boom shakes after it is closed in place, users can reduce this value.
2.6 Learning Speed	25	10-50	The speed at which the the barrier gate begins to learn the down limit position after the power is turned on for the first time.

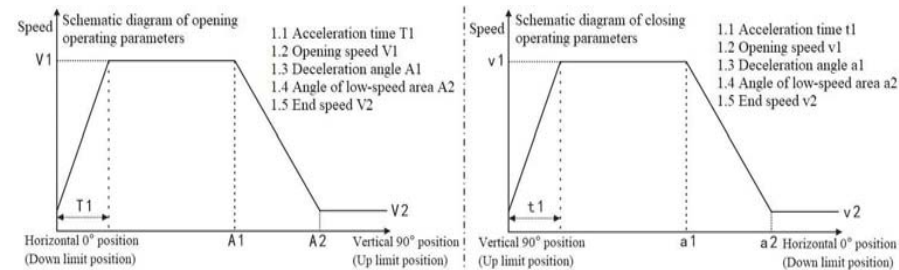

#### 1.3 The Deceleration Angle

It is used to set the angle at which deceleration begins in the opening process. The angle is 0 degree when the barrier gate is opened in place(in horizontal position) and 90 degrees when it is closed in place(in vertical position). This parameter indicates that deceleration begins when the barrier gate is opened to this angle. If the boom shakes after it is opened in place, users can reduce this value. (Chapter 2.3 has the similar operation)

#### 1.4 The Angle of Low-speed Area

It is used to set a low-speed area in the opening process. When the opening angle reaches the set angle, the barrier gate will run at the end speed that chapter 1.5 set until it is opened in place. If the value is 90, the function is invalid. If the boom shakes after it is opened in place, users can reduce this value appropriately. (Chapter 2.4 has the similar operation)

#### 1.5 The End Speed

This is the minimum speed at which the barrier gate is opened in place. The barrier gate will run at the this speed until it is opened in place. If the parameter is set too large, the boom will shake when it is opened in place. (Chapter 2.5 has the similar operation)

#### 4.4.3. Quick operation parameter

Sub-menu	Model Type	Remarks
Auto setting of opening and closing operating parameter according to different models	DZ04VF	Quickly set parameters according to different models

**Notice:** this device can quickly set the opening and closing operating parameters according to the model types, which shorten the debugging time. If the effect is still not good after setting, you can adjust the corresponding parameters appropriately.



#### 4.4.4. Position setting

Sub-menu	Range	Remarks
4.1 Position learning mode	Find up and down limit/ find up limit only/ find down limit only	Learning mode after the power is turned on for the first time. For straight boom which is over 5 meters long or fence boom, it is recommended to select the "Find up limit only" mode; when the barrier gate is installed under an eaves, please select the "Find down limit only" mode.
4.2 Manual learning f up and down Limit	None; operate according to the prompts on the screen.	In manual mode, learn the up and down limit.
4.3 Manual learning of up limit	None; operate according to the prompts on the screen.	In manual mode, learn the up limit only.
4.4 Manual learning of down limit	None; operate according to the prompts on the screen.	In manual mode, learn the down limit only.
4.5 Horizontal fine adjustment	1-3000	Boom horizontal fine adjustment
4.6 Vertical fine adjustment	1-3000	Boom vertical fine adjustment

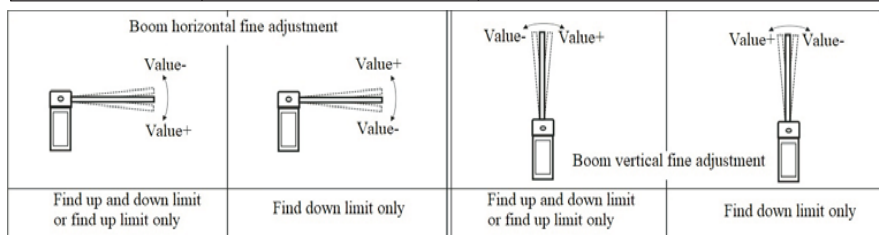

#### 4.4.5. Remote controller learning

Sub-menu	Remarks
5.1 How to match code	Press the setting button to enter the learning state of the remote controller, and press any buttons of the remote controller to learn. Users can learn up to 60 remote controllers
5.2 How to clear code	Press the Setting button to invert the color of the +- symbol on the screen, and press ▲ and ▼ at the same time to clear the code of all remote controllers.

#### 4.4.6. RS485 setting

Sub-menu	Defaults	Range	Remarks
----------	----------	-------	---------

6.1 Address	1	0-255	When RS485 is online, the host is set to 0, and the slave is set to 1. When it is connected to the host computer, 1-255 can be set.
6.2 Baud Rate	19200	9600/19200	19200 baud rate is a multi-functional communication protocol; 9600 is compatible with the protocol of old DZ5 control board.

**Notice:** please contact the manufacturer for detailed communication protocol.

#### 4.4.7. Auto-closing function

Defaults	Range	Remarks
OFF	0-255, 0 is OFF	auto-closing time when no vehicle is passing. Unit: second.

**Notice:** when no loop detector or radar is installed, this function can be used for auto-closing. It can also be used with counting function to prevent the situation that the barrier gate is not closed because of over-counting.

#### 4.4.8. Counting function

Defaults	Range	Remarks
OFF	OFF-ON	store the times of opening signal, and the barrier gate will be auto closed when the number of the leaving vehicles is the same as the number of the opening signal.

#### 4.4.9. Sensitivity of auto-reversing on obstacle

Defaults	Range	Remarks
100	50-400	Auto-reversing response time: the bigger it is, the lower the sensitivity is; the smaller it is, the higher the sensitivity. Unit: millisecond.

**4.4.10. Restore factory defaults:** press the setting button to invert the color of the +- symbol on the screen, and press ▲ and ▼ at the same time to restore the default values of all parameters.

#### 4.5. "Advanced Menu" Command List

"Advanced Menu" access method: simultaneously long press the "☰" and "■"

button for 2 seconds to enter the menu setting status.



## Warning

**Advanced menu is for professional technician, general users should use it with caution!**

### 4.5.1. Auto-aging test

Sub-menu	Defaults	Range	Remarks
1.1 Time Interval	OFF	0-5, 0 is OFF	Time interval for auto aging test; unit: second.
1.2 Boom up angle	0	0-90	Boom up angle after switching from off to on. If the value is odd, it will keep switching from off to on all the time, if the value is even, it will turn from off to on once and then completely turn off once again, and repeat continuously.

### 4.5.2. Auto-open when power off

Sub-menu	Defaults	Range	Remarks
2.1 Low voltage actuation time	OFF	0-5000, 0 is OFF	The time when the voltage is lower than the set threshold and continues to exceed the threshold, it will turn on automatically. Unit: millisecond.
1.2 Low voltage threshold	21	15-23	The operating voltage is lower than the threshold; unit: V.

**Notice:** This function needs to be equipped with a backup power module.

### 4.5.3. Motor setting

Sub-menu	Defaults	Range	Remarks
3.1 Power value when closing	0%	0-12%	When the spring force is not enough and the boom may sag down when the barrier gate closes at down limit position, users can increase this value appropriately to get some force.
3.2 Motor type	129 Forward Rotation	129 Forward/Reverse -B03 Forward/Reverse	It is used for matching the motor type. This model must be set as 129 forward rotation, otherwise the operation will be abnormal.

### 4.5.4. Relay output mode

The control board has two limit output relays. Users can set different output modes to

meet different application requirements.

**Limit output:** when the barrier gate opens to up limit position, the open relay will close; when the barrier gate closes to down limit position, the down limit relay will close; during the barrier gate opening or closing or stopping, these two relays are disconnected. This function can be used with the system to monitor the status of the barrier gate.

**Alarm for boom swinging away:** in this mode, "infrared signal input" and "GND" interface are used as the signal interface of boom installation. If they are short-circuited, it means that the boom works normally; if disconnected, it means that the boom swings away. When the boom swings away, the barrier gate will open to up limit position automatically and after then the up limit relay will stay in closing status. When the boom is installed correctly and work normally (the signals are short-circuited) again, the up limit relay will work normally.

**Notice:** This function needs to be equipped with inductive switch for detecting the status of the boom.

**Alarm against artificial lifting boom:** in this mode, the up limit relay is used as an alarm signal output. When the barrier gate closes at down limit position, if the boom is artificially lifted up to a certain angle, the up limit relay will be closed for 15 seconds as an alarm output. An external alarm can be connected for alarm.

**Down Limit Pulse Signal :** After the boom runs to down limit position, the down limit relay will send closing signal for a second. This function can be used as the opening signal for the other barrier gate or other control system. The up limit relay was closed when boom falls down, the signal during boom falling down and boom at down limit position can be used as R&G light signal, or used for detecting the barrier gate running status.

### 4.5.5. Buffer time for boom from closing to opening

Pressing open button in the process of closing, this parameter is used to set the buffer time of the controller from receiving the command to starting to open.

### 4.5.6. Buffer time of barrier gate stopping

Pressing stop button in the process of barrier gate opening or closing, in order to make the barrier stop smoothly, set a buffer time. This time is the time from the barrier gate receiving the stop command to stopping completely.

### 4.5.7. Open the barrier gate by remote control to enter the motorcade mode

Open the barrier gate by remote control to enter motorcade mode directly. At this

time, the loop detector is invalid until closing the barrier gate. Closing barrier gate both by wire control and by remote control can exit the motorcade mode. Opening the barrier gate by wire control does not enter the motorcade mode. The default is "OFF".  
 Tip: When it is set to "OFF" in the up limit position, long press the "UP" button of the remote controller for 4 seconds can also enter the motorcade mode; or pressing "STOP" button on the controller with the program version of "10824" or above at the up limit position can also enter this mode.

**4.5.8. Valid time of loop detector signal**

In the process of opening or up limit position, the duration time of the loop detector signal needs to exceed the setting time, and the auto-closing action will be executed after the loop detector signal disappears, avoiding that the loop detector signal is too short and triggers the auto-closing action to hit the vehicles. The default time is 100ms. Range: 20ms-400ms.

**4.5.9. Beep of Loop detector signal**

There is loop detector signal (there is vehicle on the loop wire) when boom is at up limit position, the buzzer will emit a hint tone. "ON" has a sound, and "OFF" has no sound. "ON" is default.

**4.5.10. Failure angle of loop detector anti-smashing**

During the closing process, when the boom arrives at the setting angle from the horizontal level, it will not respond to the signal of loop detector, to prevent vehicle from being followed by other vehicles, and can also prevent the misoperation of the loop detector from triggering the opening of the barrier gate. The default value is 5 degrees.

**4.5.11. Failure angle on obstacle**

During the closing process, when the boom arrives at the setting angle from the horizontal level, if the boom meets on obstacle, it will not respond to barrier gate opening. The default value is 10 degrees.

**4.5.12. Switching angle of R&G light**

When the boom opens to the setting angle, the relay of R&G light will close. The default value is 60 degrees.

**4.5.13. Wire control signal type measurement**

"Infrared photocell", "loop detector/radar" and "stop" signals of the wire control

interface can be set to normal open input and normal close input, and the default is normal open input.

**5. Common Malfunctions and Solutions**

Malfunction Phenomenon	Possible Causes	Solution
The opening and closing speed is too fast for the first time after power on	Regular menu 1.6/2.6 learning speed value is too large	Reduce the corresponding value
In manually finding limit, boom can't run to limit position, and the buzzer sounds	Regular menu 1.6/2.6 learning speed value is too small	Increase the corresponding value and try again
Prompt: The motor sensor is not detected	The motor sensor plug is not plugged in or the wire is loose	Plug well the motor sensor
	Motor sensor failure	Replace the motor
The control board resets when the barrier gate is running	Short circuit inside the motor	Measure the resistance of each two wires (white, yellow and red) of the motor phase line by a multimeter, to check if the resistance numbers are the same
	Control board failure	Replace the control board
Auto reverse during the closing process.	Prompt: meeting obstacle	increase the value of item 4.4.9 in regular menu
	Signal error of loop detector or radar	Check whether the loop detector or radar signal indicator flashes by mistake
Boom shakes a lot at up limit position	Opening speed in up limit position is large	Reduce the value of 1.5 in regular menu
	Opening deceleration angle is large	Reduce the value of 1.3/1.5 in regular menu at the same time
	Opening speed is high	Reduce the value of 1.2 in regular menu

Boom shakes a lot at down limit position	Closing speed in down limit position is large	Reduce the value of 2.5 item in regular menu
	Closing deceleration angle is small	Reduce the value of 2.3/2.5 in regular menu at the same time
	Closing speed is high	Reduce the value of 2.2 in regular menu
Remote control distance is short	The battery voltage of remote controller is too low	Replace the batteries
	High-voltage wires or strong electromagnetic causing serious interference near the barrier gate	Replace the high-power remote controller
Remote control learning failed	The remote controller does not match the receiver	Contact the manufacturer
	The order of the remote controller is wrong	Relearn after clearing the code of remote controller

## **6. Warranty and Service Items**

- 6.1. Free service is offered for component parts in one year warranty time. (not includes the barrier boom or remote)
- 6.2. Lifetime service with charge accordingly.
- 6.3. Technical questions are supported.
- 6.4. The below items and situations are not included in the range of free service:
- 6.4.1. The user does not follow the instruction and cause any damage of the product.
- 6.4.2. The power supply is not stable, over the range of permitted voltage or not accordant to safety electric using standard.
- 6.4.3. The user installs or uses the product in wrong methods, cause damage to the appearance of product.
- 6.4.4. Natural disaster causes damage to the product.
- 6.4.5. Warranty time is over.
- 6.4.6. Service items are out of our promises.

## **7. Maintenance**

- 7.1. Keep the barrier gate clean.
- 7.2. Check the joints every month in case of any loose parts.
- 7.3. Check the balance status of spring after the barrier gate running 300,000 times or

6 months (whether the boom is shaking when boom moving), and readjust the balance. And change new springs after running 500,000 times or 12 months, to avoid spring breaking due to excessive fatigue.

7.4. Check the easily worn-out parts every half year and renew it.

7.5. Remote control distance will be shortened or not work in cases like big object screening, battery exhausting, extreme weathers.

## **8. Packing List**

Name	Specification	Quantity	Unit	Application
Screws, Nuts, Flat Pad	M12*70	2	sets	Fixing the boom
Boom Fixing Bar		1	pcs	Fixing the boom
Boom Holder Plastic Cover		1	sets	Optional
Cabinet Fixing Bar		2	pcs	Fixing the cabinet
Expansion Screws	M16*150	4	sets	Fixing the cabinet
Support Post		1	pc	Optional
Radio Emitter		1	pcs	Optional
Keys		2	pcs	For cabinet door
Remote Controller		2	pcs	
Manual		1	pcs	

### 9. Spring Selection Table

Boom Type	Boom Length (Meters: M)	Spring Diameter $\Phi$ (mm)	Quantity of Springs (pieces)	Remark
Straight Boom without Rubber	$6 \geq L \geq 5.8$	3.8	5	
	$5.7 \geq L > 5$	3.8	4	
	$5 \geq L \geq 3.8$	3.8	3	
	$3.7 \geq L \geq 2.8$	3.8	2	
Straight Boom with Rubber	$6 \geq L \geq 5.5$	3.8	5	
	$5.4 \geq L \geq 4.8$	3.8	4	
	$4.7 \geq L \geq 3.8$	3.8	3	
	$3.7 \geq L \geq 2.8$	3.8	2	
Articulated Boom	$5 \geq L \geq 4.5$	3.8	4	
	$4.4 \geq L \geq 3.8$	3.8	3	
	$3.7 \geq L \geq 2.8$	3.8	2	
Fence Boom, Two-levels	$4.5 \geq L \geq 4.3$	3.8	6	
	$4.2 \geq L \geq 3.8$	3.8	5	
	$3.7 \geq L \geq 3.3$	3.8	4	
	$3.2 \geq L \geq 2.8$	3.8	3	
Fence Boom, Three-levels	$4 \geq L \geq 3.8$	3.8	6	
	$3.8 > L \geq 3.3$	3.8	5	
	$3.3 > L \geq 2.5$	3.8	4	