

# LCD display advanced digital temperature controller

## User Manual

Please read this manual carefully and keep this manual for further reference

### Features

- LCD three color VA display, bar graphic, output percentage MV1/MV2 or feedback MVFb display
- 0.2% measuring accuracy, maximum resolution 0.1 for TC and RTD input
- Output: relay, SSR drive, analog, triac, re-transmission
- Alarm: AL1/AL2 relay output, excitation, non-excitation, delay output, alarm lock function  
Alarm mode: PV, deviation, absolute, band, alarm standby, PV deviation alarm ramp start-up alarm, ramp end alarm, Loop break alarm, heater break alarm
- Control mode: PID with auto-tuning, on/off, heating or cooling, heating+cooling, 3 wires proportional valve control, valve control with feedback signal, output restrain
- Program version: PID mode, ramp up mode, temp constant mode, soft-start
- Add-on feature: auto/manual control, run/stop function, even SV input
- Special features: all parameters distributed in three levels, parameters can be manually designate to different level
- Communication: RS-485, modbus-RTU, pattern 8-(N,0,E)-(1,2)
- Ambient temp 0-50°C, humidity 0-80%RH

## 1: Model number and ordering information

Please check this ordering information and specify the code when order with us

Model	TX4S (48mm*48mm)
Item number( Panel size: width x height)	TX4H (48mm*96mm)Vertical
	TX4W (96mm*48mm)Horizontal
	TX4M (72mm*72mm)
	TX4L (96mm*96mm)

## 1: Controller type

U	Standard PID type
T	Temperature constant mode(with timer)
R	Ramp and soak mode(with timer)
X	Motor valve direct/reverse control version(two relays)

## 2: OUTPUT 1

R	Relay output
V	SSR Drive/Voltage pulse output
D	4-20mA output
E	0-10Vdc
F	0-20mA
5	0-5Vdc
7	1-5Vdc
T	Traic single phase zero-crossing trigger
A	<b>Relay output, for motor valve direct act control</b>

## 3: OUTPUT 2(output 2 is only available for heating+cooling controller)

N	No output2( For single output controller, choose code N)
R	Relay output
V	SSR Drive/Voltage pulse output
D	4-20mA output
E	0-10Vdc
F	0-20mA
5	0-5Vdc
7	1-5Vdc
T	Traic single phase zero-crossing trigger
A	<b>Relay output, for motor valve reverse act control</b>

## 4: Number of Alarms

1	1 alarm
2	2 alarms
3	3 alarms

## 5: Power Source

96	85~265Vac 50/60HZ
24	24Vac/24Vdc

## 6: PV/SV re-transmission

N	No re-transmission function	F	4-20mA re-transmission via AU3
A	4-20mA re-transmission via OP2	G	0-20mA re-transmission via AU3
B	0-20mA re-transmission via OP2	K	0-10Vdc re-transmission via AU3
E	0-10Vdc re-transmission via OP2		

## 7:RS-485 Communication

N	No communication feature
K	RS-485 modbus RTU communication

## 8:AUX power source

N	No aux power	B	24Vdc grounded	D	12Vdc grounded
A	24Vdc isolated	C	12Vdc isolated		

## 9:Position feedback(analog feedback input from INP2)

N	No position feedback	A	4-20mA	B	0-20mA
C	0-5Vdc/potentiometer	D	1-5Vdc	E	0-10Vdc

## 10:Remote SV setting

N	No remote SV feature	A	4-20mA via INP2	B	0-20mA via INP2
C	0-5Vdc via INP2	D	1-5Vdc via INP2	E	0-10Vdc via INP2
F	4-20mA via INP3	G	0-20mA via INP3	H	0-5Vdc via INP2
J	1-5Vdc via INP3	K	0-10Vdc via INP3	W	D1/D2 terminals event input

## 11:Manual output% remote setting

N	No remote SV feature	A	4-20mA via INP2	B	0-20mA via INP2
C	0-5Vdc via INP2	E	0-10Vdc via INP2	F	4-20mA via INP3
G	0-20mA via INP3	H	0-5Vdc via INP3	K	0-10Vdc via INP3

## 2. Size and mounting

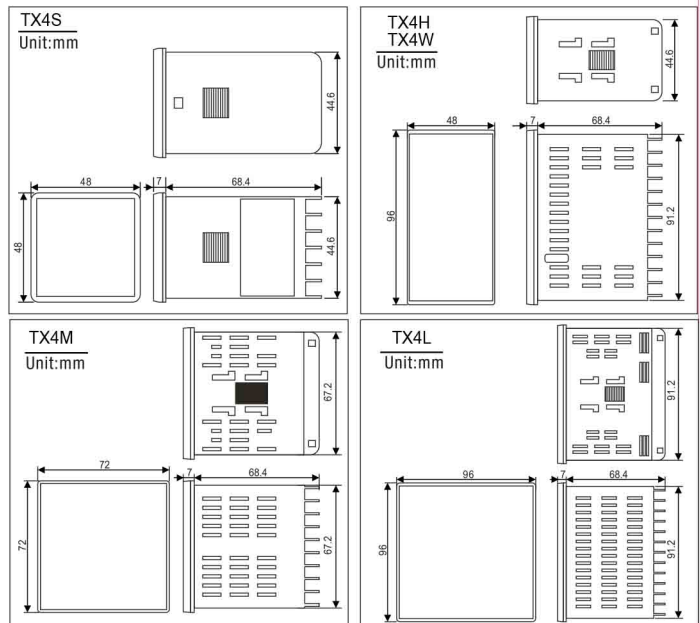

## 3. Wiring diagram

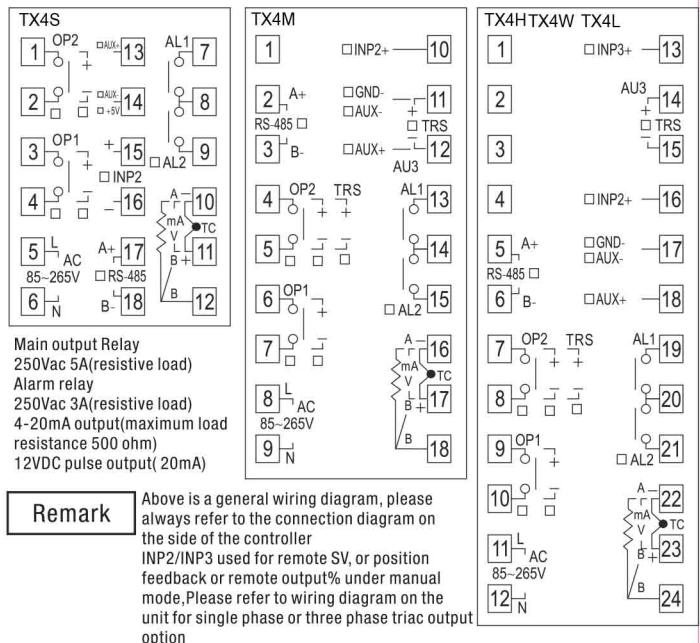

## 4. Panel description

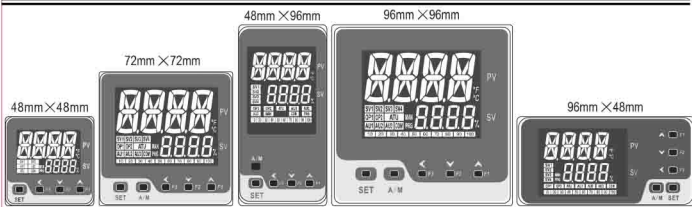

PV window: display PV and parameter notation  
 SV window: display SV and parameter value  
 Bar graphic: indicate output%, feedback value or re-transmission value

SET: Main function key  
 A/M: Auto/manual switch key and enter key  
 ◀ : Shift key (F3 function key, such as ATU fast initiated or go back to previous parameter)  
 ▼ : Numeric decrease (F2 function key)  
 ▲ : Numeric increase (F1 function key, Run/Stop)  
 SV1: Event input SV1 indication  
 SV2: Event input SV2 indication  
 SV3: Event input SV3 indication  
 SV4: Event input SV4 indication  
 SV1 and SV2 light together indicate remote-SV

OP1: Indicate OP1 status  
 OP2: Indicate OP2 status  
 ATU: Indicate auto-tuning status  
 AU1: AL1 alarm status  
 AU2: AL2 alarm status  
 AU3: Reserved light  
 MAN: Manual control/soft-start indication  
 COM: Communication indication  
 PRG: Temp constant mode indication  
 Ramp and soak indication

## 5. Setting and programming

### 5.1 Power on initialization

Power on stage shows the software version and edition, input type and setting value range



Notation	K	E	J	N	Wu3_Re25	S	t
Sensor type	K	E	J	N	Wu3_Re25	S	t
Range	-15 to 1300°C 0 to 2600°F	-15 to 800°C 0 to 1560°F	-15 to 1000°C 0 to 1950°F	-15 to 1300°C 0 to 2600°F	0 to 2200°C 0 to 3276°F	0 to 1600°C 0 to 3000°F	-15 to 400°C 0 to 782°F

  

Notation	r	b	AN1	AN2	F3	F4	PL
Sensor type	r	b	DC0-50mV	DC10-50mV	Reserved	Reserved	PL100
Range	0 to 1769°C 0 to 3216°F	0 to 1800°C 0 to 3276°F	-1999 to 9999	-1999 to 9999	Reserved	Reserved	-199 to 800°C -326 to 1472°F

### 5.1 SV configuration and parameter configuration

#### 5.2.1 How to change the SV setting value, use the short cut key.

For example: change the SV from 0 to 200°C

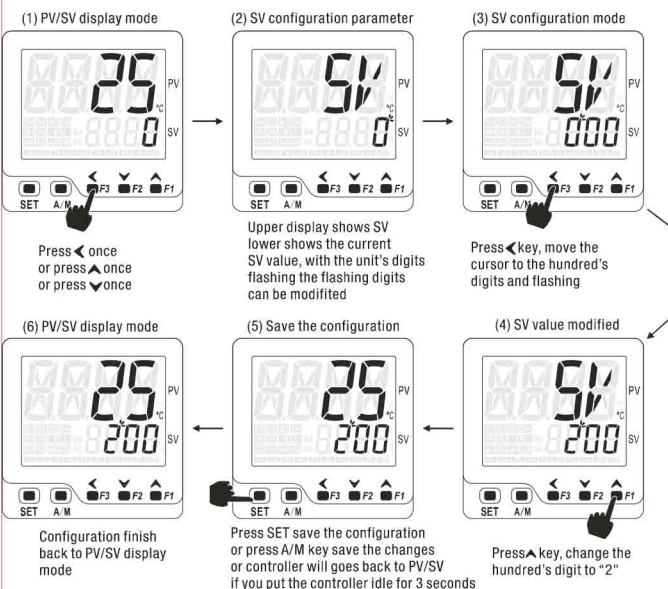

Remark 1: SV setting parameter can be assigned to different parameter menus, refer to S.F00 parameter for details

Remark 2: SV remote setting details, refer to "10. SV remote setting for more information"

#### 5.2.2 How to configure all configurable parameters

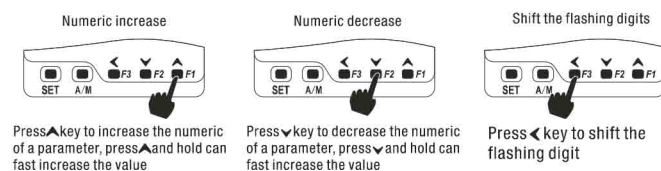

### 5.2.3 Shift between parameters and go back to previous parameter

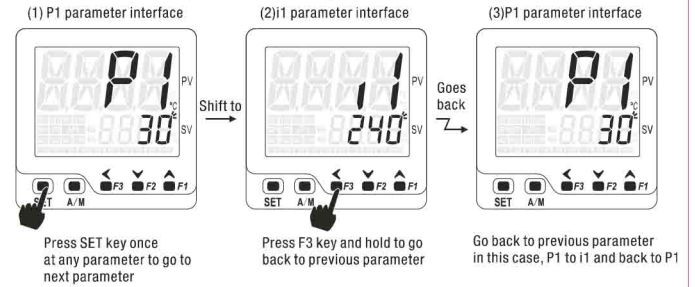

### 5.2.4 Save configuration and go back to normal PV/SV display mode

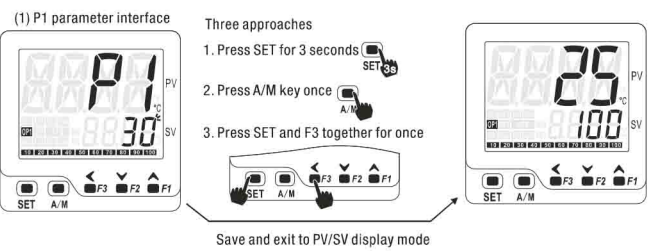

## 6. Parameter menu

### 6.1 Factory default parameter menu

#### 6.1.1 Quick start menu level 1 (Press SET once to enter this menu)

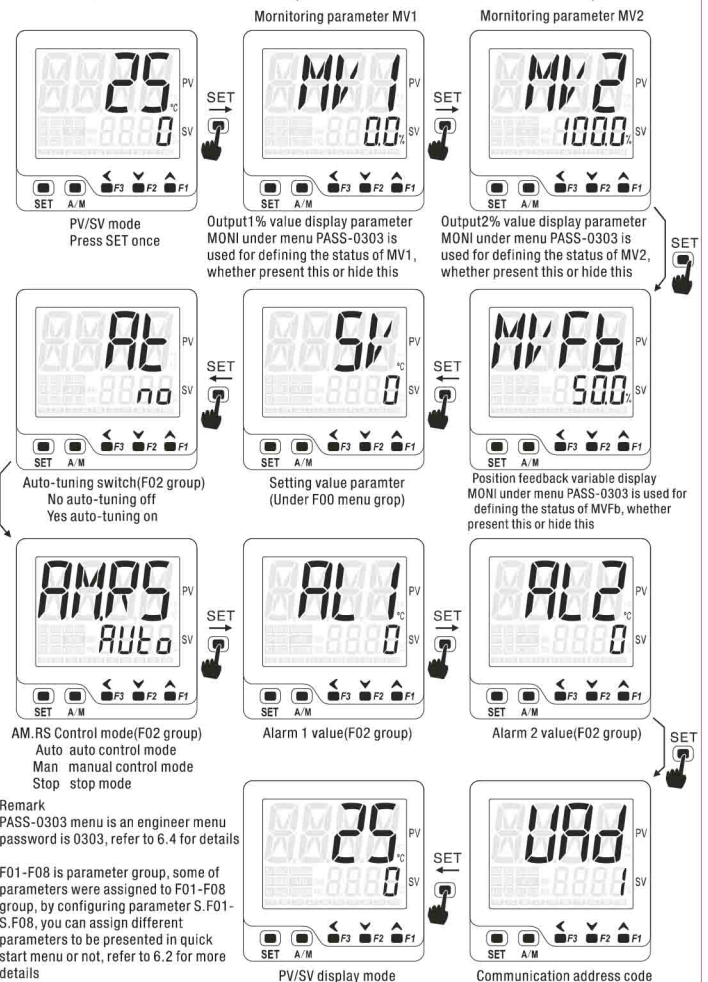

#### 6.1.2 Quick start menu level 2 (Press SET for 3 seconds to enter)

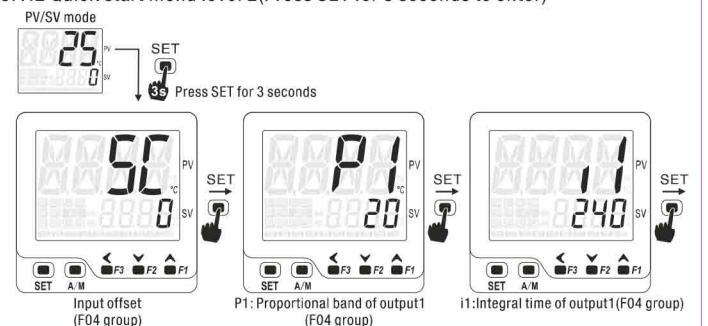

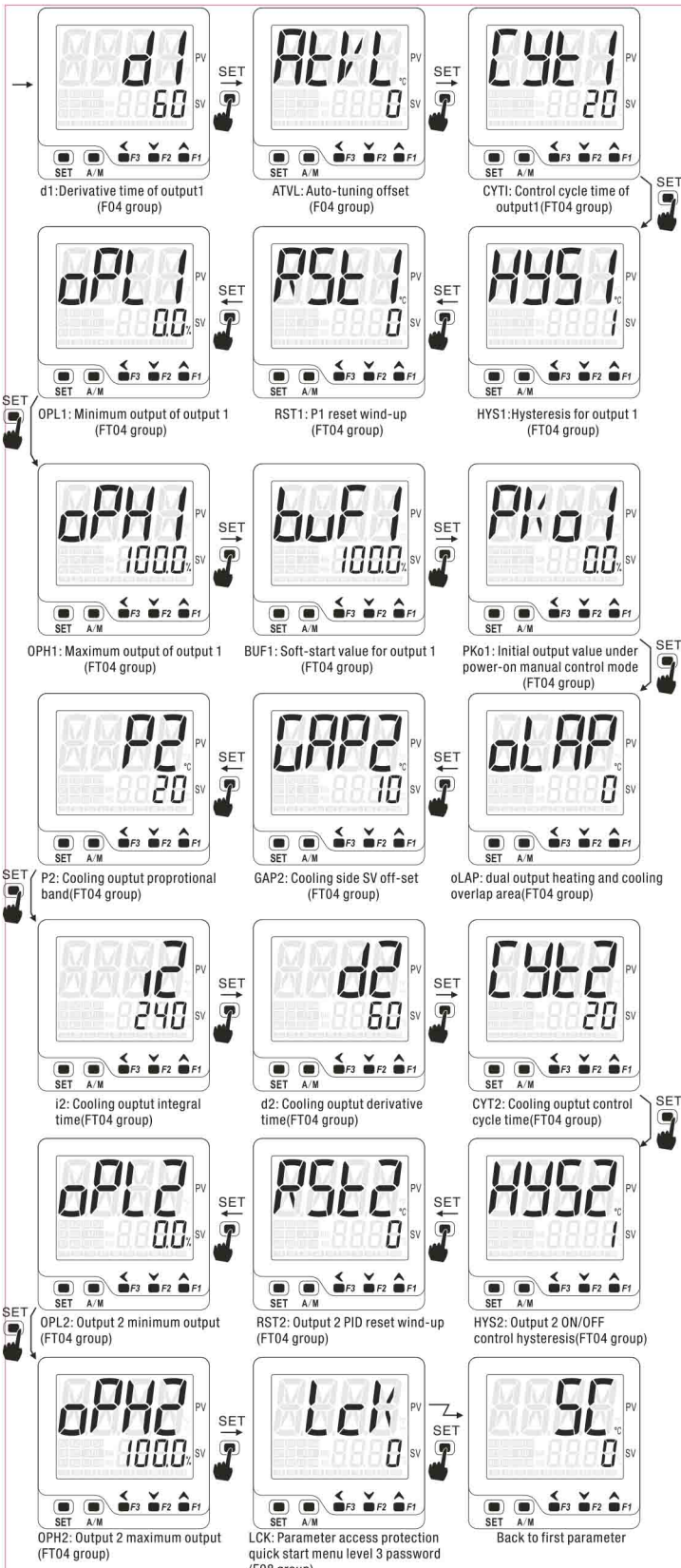

## 6.2 Basic functional parameter menu(F menu)

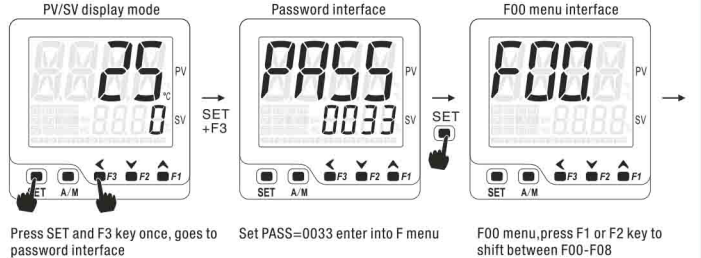

Notation	Name	Description	Default
SV	setting value	Range defined by(LSPL to USPL)	0
SF00	define the status of F00 group parameters	0: Do not present F00 under quick start menu Press F1, F2, F3 to SV setting mode 1: Present F00 at quick start menu level 1 2: Present F00 at quick start menu level 2 3: Present F00 at quick start menu level 3	0

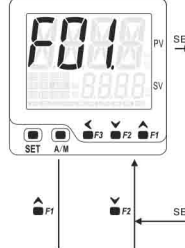

Notation	Name	Description	Default
SV1	Event input SV1	SV setting configured by external D1/D2 terminals SV1 D1: open D2: open, SV=SV1	1
SV2	Event input SV2	SV setting configured by external D1/D2 terminals SV2 D1: open D2: close, SV=SV2	2
SV3	Event input SV3	SV setting configured by external D1/D2 terminals SV3 D1: close D2: open, SV=SV3	3
SV4	Event input SV4	SV setting configured by external D1/D2 terminals SV4 D1: close D2: close, SV=SV4	4
SF01	define the status of F01 group parameters	0: Do not present in quick start menu 1: Present F00 at quick start menu level 1 2: Present F00 at quick start menu level 2 3: Present F00 at quick start menu level 3	0



Notation	Name	Description	Default
AL	AT Auto-tuning	No.: Auto-tuning off Yes: Auto-tuning on	no
AMRS	AM, RS Operating mode	Auto.: auto control mode MAN: manual control mode StoP: stop mode	Auto
AL1	AL1 Alarm 1 value	Alarm value for alarm 1, range -1999~9999	10
AL2	AL2 Alarm 2 value	Alarm value for alarm 2, range -1999~9999	10
UAD	UAD Device address	Define device address in RS-485 system	1
SF02	define the status of F02 group parameters	0: Do not present in quick start menu 1: Present F00 at quick start menu level 1 2: Present F00 at quick start menu level 2 3: Present F00 at quick start menu level 3	1



Notation	Name	Description	Default
RAMP	Ramp Ramping up rate	Ramp rate under ramp up heating mode Unit is °C/minute	1
t1	t1 timer range	t1 is a time duration for temperature constant mode or ramp up mode minutes or seconds, t1=0, temperature constant mode disabled parameter t1UN under PASS-0303 define the t1 unit	0
SF03	define the status of F03 group parameters	0: Do not present in quick start menu 1: Present F00 at quick start menu level 1 2: Present F00 at quick start menu level 2 3: Present F00 at quick start menu level 3	0



Notation	Name	Description	Default
SC	SC Input offset	Input offset, to compensate the error caused by sensor Range, for temp: -199~199, for analog, -1999 to 1999	0
P1	P1 Proportional band of output 1	Proportional band of output 1, range 0-800 output 1 switch to ON/OFF control when P1=0, Hysteresis is HYS1	20
d1	d1 Derivative time	Derivative time of output 1, range 0-3600 seconds When d1=0, derivative off	30
ALVL	ALVL Auto-tuning SV offset	Shift the SV value lower to prevent large overshoot during auto-tuning process range -199-199	0
CYT1	CYT1 Cycle time for output 1	cycle time for output 1, CYT1=20 seconds for relay CYT1=2 seconds, CYT1 not applicable for analog output	20
HYS1	HYS1 Hysteresis for output 1	When P1=0, ON/OFF control, HYS1 0.1~900 Heating: OP1 stop PV>SV OP1 active when PV<SV-HYS1 Cooling: OP1 active when PV>SV+HYS1 OP1 stop PV<SV	0
RST1	RST1 Time proportional reset	When t1=0, d1=0, pure proportional control, RST1 is reset value Heating, out 1%=(SV+rst1-PV)/P1*100% Cooling, out 1%=(PV-SV-rst1)/P1*100% this used to suppress overshoot at start-up for PID control Heating, suppress more when rst 1 gets smaller Cooling, suppress more when rst 1 gets bigger range: -199~199	0
OPL1	OPL1 minimum output for out1	Minimum output value 0.0 to 100.0%	0.0
OPH1	OPH1 maximum output for out1	Maximum output value 0.0 to 100.0%	100.0
BUF1	BUF1 Output 1 restrain	Output restrain for analog output, output restriction, only applicable for analog output controller for example, if buf=5%, means the output changing ratio will be less than 5% per second	100.0
PK01	PK01 Initial output %	Define the output ratio when temperature configured as manual output after power on	100.0
oLAP	oLAP heating/cooling overlap	heating/cooling control overlap, range 0-100, overlap area is (SV-OLAP)-(SV+OLAP)	2

To the next page

### 6.1.2 Quick start menu level 3(custom menu,access with password)

This is a customized menu, you can put those frequently used parameters which likely be manipulated under this menu, password is required if you want to access to this menu this will prevent unauthorized access and configuration

Lck: password to access menu level 3 Customized parameters, there is no parameters under this menu as factory default

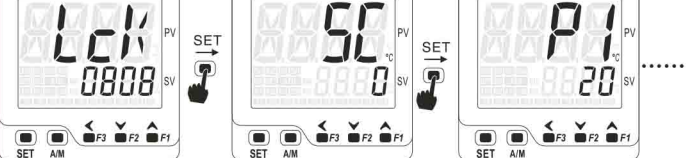

Lck: quick start menu(F08)  
S.F08 parameter defines the presence of this menu when Lck=0808, press SET key

Remark: F01-F06, parameters were distributed to these groups  
S.F01-S.F06 used to define the presence of these parameter groups refer to "6.2 basic functional menu(F menu)" for more details

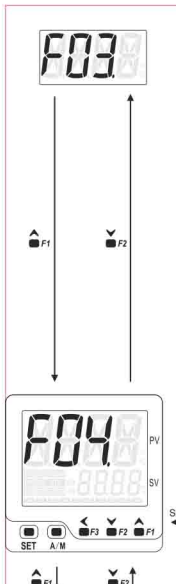

From the previous page

Notation	Name	Description	Default
GAP2	Cooling control SV offset	Define the cooling control SV value cooling control SV=SV+GAP2. Range: 0~200 For example, SV=100, GAP2=10 Then cool side SV=100+10	0
P2	P2 for cooling control	Proportional band for output 2, unit is degree range 0~800, P2=0 for ON/OFF control mode	20
I2	Integral time I2 for output 2	Integral time for output 2 range 0~3600 seconds I2=0 integral action off	210
d2	Derivative time for output 2	Derivative time for output 2 range 0~3600 seconds d2=0 derivative action off	30
CYCL2	Control period for output 2	Control period for output 2, 20 seconds for relay output, 2 seconds for SSR drive output	20
HYS2	Hysteresis for output 2	When P2=0, on/off control for out2.HYS2.range 0.1~900. OP2 active when PV>SV+GAP2+HYS2 OP2 stop when PV<SV+GAP2	0
RST2	time proportional reset, rSt2	When I2=0, d2=0, proportional control out2 %=(PV-SV-GAP2-rst2)/P2*100% suppress the overshoot after power on range:-199~199	0
oPL2	Minimum output for out 2	Minimum output for output 2 range 0.0~100%	0.0
oPH2	Maximum output for out 2	Maximum output for output 2 range 0.0~100%	100.0
SFO4	Define status of F04 group parameters	0: Absent 1: Present in quick start menu 1 2: Present in quick start menu 2 3: Present in quick start menu 3	2

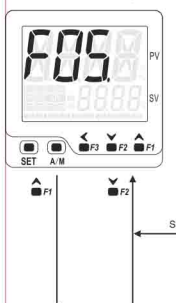

F05 group parameters for controller with soft-start function only

Notation	Name	Description	Default
SFSV	Soft-start SV	SFSV range:-199~3275 SIME range: 0~100 minutes Sout range: 0.0~100.0%	0
SIME	Soft-start period	Soft-start function 1. Power on, heating control, if PV<SFSV, soft start active 2. Power on, cooling control, if PV>SFSV, soft start active 3. MAN indicator flashes, out% = "Sout" value 4. PID heating, when PV>SFSV or SIME time reached, soft-start off 5. PID cooling, when PV<SFSV or SIME time reached, soft-start off 6. MAN indicators off when soft-start terminated 7. SIME=0, soft-start function disabled	0.0
Sout	Soft-start out%	Soft-start out%	0.0
SFO5	Define status of F05 group parameters	0: Absent 1: Present in quick start menu 1 2: Present in quick start menu 2 3: Present in quick start menu 3	0

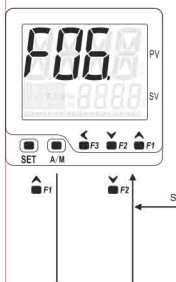

F06 group parameters for LBA(loop break alarm)and HBA(heater break alarm) only

Notation	Name	Description	Default
LbAL	LBA check time	Under heating mode(100% output),if the temperature did not increase LbAb within LbAT period, LBA will be triggered	80
LbAB	LBA temperature differential	Under cooling mode(100% output), if the temperature did not drop LbAb within LbAT period, LBA will be triggered	2
HbAL	Heater short circuit time	Under heating mode, if temperature increase HbAb within HbAT period at output 0% HBA goes off	180
HbAB	Temperature differential	Under cooling mode, if temperature drops HbAb within HbAT period at output 0% HBA goes off	10
SFO6	Define status of F06 group parameters	0: Absent 1: Present in quick start menu 1 2: Present in quick start menu 2 3: Present in quick start menu 3	0

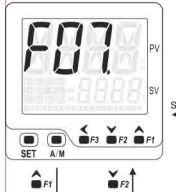

F07 group parameters

Notation	Name	Description	Default
1LR	ALM1 interlock	if alarm 1 interlocked, 1LR=1 put 1LR=0 can disengage the interlock	0
2LR	ALM2 interlock	if alarm 2 interlocked, 1LR=2 put 2LR=0 can disengage the interlock	0
SFO7	Define status of F07 group parameters	0: no shortcut for interlock disengage 1: shortcut for interlock disengage available Press F1 and F2 at the same to quick access to 1LR and 2LR	0



F08 group parameters

Notation	Name	Description	Default
LCK	Access protection and password for quick start menu 3	=0/1: all parameters can be modified =2: F06 group of parameters locked =3: F05, F06 parameters locked =4: F04, F05, F06 parameters locked =5: F03, F04, F05, F06 parameters locked =6: F02, F03, F04, F05, F06 parameters locked =7: F01, F02, F03, F04, F05, F06 parameters locked =8: F00, F01, F02, F03, F04, F05, F06 parameters locked =0808: Press SET to quick start menu 3	0
SFO8	Define status of F08 group parameters	0: Absent 1: Present in quick start menu 1 2: Present in quick start menu 2 3: Present in quick start menu 3	2

- Three approaches to exist and save the configuration under F menu
- 1: Press SET key for 3 seconds
  - 2: Quick press A/M key once
  - 3: Press SET and F3 at the same time

## 6.2 Engineer parameter (PASS-0101 menu)

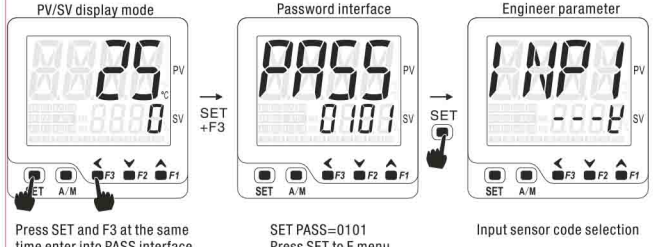

Press SET and F3 at the same time enter into PASS interface  
SET PASS=0101 Press SET to F menu  
Input sensor code selection

Depends on the specific functions some of parameter may or may not be available

Notation	Name	Description	Default	Remark				
INP1	Input sensor code selection INP1							
	Symbol	E	J	N	S	t		
	input	K	E	J	N	S	t	
	range	-15 to 1300°C 0 to 3276 °F	-15 to 800°C 0 to 1560 °F	-15 to 1000°C 0 to 1950 °F	-15 to 1300°C 0 to 2600 °F	0 to 2200°C 0 to 3276 °F	0 to 1600°C 0 to 2900 °F	-15 to 400°C 0 to 782 °F
	Symbol	r	b	AN1	AN2	F3	F4	PE
	input	r	b	DC0-50mV	DC10-50mV	Reserved	Reserved	PI100
	range	0 to 1789°C 0 to 3216 °F	0 to 1800°C 0 to 3276 °F	-1999 to 9999	-1999 to 9999	Reserved	Reserved	-199 to 800°C -328 to 1472 °F
DP	Decimal point dP	0,1,2,3	0	TC/RTD input, 0: without decimal point, 1: 1 decimal point Analog input: 0: without decimal point, 1: 1 decimal point, 2: 2 decimal points 3: 3 decimal points				
UNIT	Display unit UNIT	°C, °F, no	°C	°C: Celsius °F: Fahrenheit No: No unit				
LSPL	SV lower limit LSPL	Temp:-199~3276 Analog:-1999~9999	0	SV lower limit Remote-SV lower limit input display value				
USPL	SV higher limit USPL	Temp:-199~3276 Analog:-1999~9999	400	SV higher limit Remote-SV higher limit input display value				
PVOS	input offset PVOS	Temp:-199~199 Analog:-1999~9999	0	To compensate the input error caused by the sensor				
PVFT	Input filter strength PVFT	0 to 60	5	1-30 normal input filter strength 31-60 enhanced input filter strength				
ANL1	lower limit display for analog input	-1999~9999	0	Display for analog input at its lower limit value "ANL1"				
ANH1	higher limit display for analog input	-1999~9999	2000	Display for analog input as its higher limit value "ANH1"				
LRSL	Transmission output lower limit LRSL	-1999~9999	0	Display for re-transmission at its lower limit value				
LRSH	Transmission output lower limit LRSH	-1999~9999	400	Display for re-transmission at its higher limit value				
ALD1	Alarm mode for alarm 1	00 to 16	11	To configure the alarm mode of alarm 1				
AH1	Alarm hysteresis for alarm 1	0 to 9999	0	Hysteresis value for alarm 1				
ALT1	Alarm 1 delay time	0 to 9999 seconds	0	Alarm delay time for alarm 1 only applicable for ALD1=01~06 and 11~16, Alarm 1 will be triggered after delay time AL11				
ALD2	Alarm mode for alarm 2	00 to 16	10	To configure the alarm mode of alarm 2				
AH2	Alarm hysteresis for alarm 2	0 to 9999	0	Hysteresis value for alarm 2				
ALT2	Alarm 2 delay time	0 to 9999 seconds	0	Alarm delay time for alarm 2 only applicable for ALD2=01~06 and 11~16, Alarm 2 will be triggered after delay time AL12				
OP1	OP1 output mode	0 or 1	0	0: reverse control(heating) 1: direct control(cooling)				
BER1	OP1 analog output restriction	0, 1, 2	0	0: output restriction off 1: output restriction on 2: output restriction on when output increase, restriction off when output decrease				
PUCY	motor valve travel time	0-200 秒	60	This parameter assign the travel time for the motor valve means the time for the valve from full open to full close this is only application for motor valve without position feedback				
SSRM	Triac triggering mode	Stnd CYCL PHAS	PHAS	Stnd: SSR Drive output, zero-crossing trigger CYCL: Random trigger PHAS: Phase angled trigger				
PMD	Program execution mode	0, 1, 2	0	Only applicable for temp constant and ramp and soak mode 0: Standard mode 1: temp constant mode 2: ramp and soak mode				
TSP	TSP	0 to 9999	1	This parameter defines the temperature when the timer kicks in Temperature(TSP) for timer kicks in= SV-TSP when PV>SV-TSP, and stay for 5 seconds then timer kicks in				
PEND	PEND	0, 1	1	=0, PID control off when timer finish =1, PID control goes on when timer finish power interruption or press F1 for 3 seconds will re-start				
IdNO	IdNO	0-255	1	Device address configuration				
bAUd	bAUd	2.4 4.8 9.6 19.2	9.6	2.4 Baud rate 2400 bps 4.8 Baud rate 4800 bps 9.6 Baud rate 9600 bps 19.2 Baud rate 19200 bps				
UCR	UCR	N,O,E	N	N: 8 data bit, + No parity+1 stop bit(8N1) O: 8 data bit, + odd parity+1 stop bit(8O1) E: 8 data bit, + Even parity+1 stop bit(8E1)				

- Alarm mode(ALD=00~16)
- 10: No alarm
  - 11: Deviation high alarm
  - 12: Deviation low alarm
  - 13: Deviation high/low alarm
  - 14: Deviation band alarm
  - 15: Process high alarm
  - 16: Process low alarm
  - 00: No alarm
  - 01: Deviation high alarm with standby function
  - 02: Deviation low alarm with standby function
  - 03: Deviation high/low alarm with standby function
  - 04: Deviation band alarm with standby function
  - 05: Process high alarm with standby function
  - 06: Process low alarm with standby function
  - 09: LBA alarm
  - 19: HBA heater short circuit alarm
  - 17: Timer kick-in alarm
  - 18: Timer finish alarm
  - 21: Setting value high alarm
  - 22: Setting value low alarm
  - 23: Process value limit value

### 6.2.1 Alarm mode details

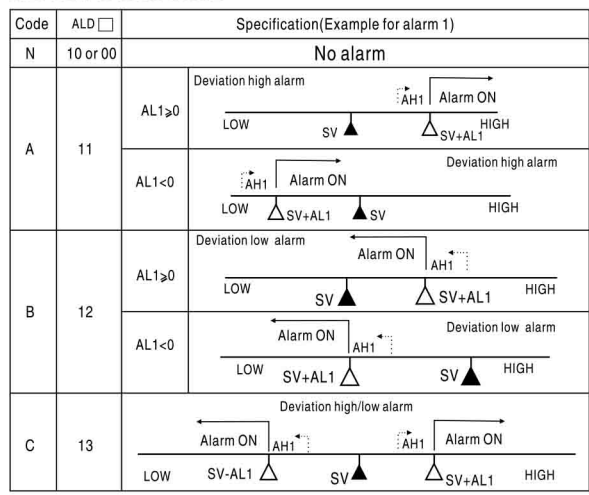

D	14	Deviation band alarm	Alarm ON	LOW SV-AL1 SV SV+AL1 HIGH
H	15	Process high alarm	Alarm ON	LOW AH1 AL1 HIGH
J	16	Process low alarm	Alarm ON	LOW AH1 AL1 HIGH
E	01	Deviation high alarm with hold action	Alarm ON	LOW SV SV+AL1 HIGH
		Deviation high alarm with hold action	Alarm ON	LOW SV+AL1 SV HIGH
F	02	Deviation low alarm with hold action	Alarm ON	LOW SV SV+AL1 HIGH
		Deviation low alarm with hold action	Alarm ON	LOW SV+AL1 SV HIGH
G	03	Deviation high/low alarm with hold action	Alarm ON	LOW SV-AL1 SV SV+AL1 HIGH
M	04	Deviation band alarm with hold action	Alarm ON	LOW SV-AL1 SV SV+AL1 HIGH
K	05	Process high alarm with hold action	Alarm ON	LOW AH1 AL1 HIGH
L	06	Process low alarm with hold action	Alarm ON	LOW AH1 AL1 HIGH
V	21	SV high alarm	When SV ≥ AL1, AL1 on, When SV < AL1 - AH1, AL1 off	LOW AH1 AL1 ON SV HIGH
W	22	SV low alarm	When SV ≤ AL1, AL1 on, When SV > AL1 + AH1, AL1 off	LOW AL1 OFF AH1 SV HIGH
P	23	Process value limit alarm		
R	09	LBA loop break alarm		
Q	19	Heater short circuit alarm		
3	17	timer kick-in alarm		
4	18	timer finish alarm		

Note: The alarm action will be suppressed right after power on even the condition is satisfied, and the alarm standby on works 1 time right after power on, the alarm will go off if the condition satisfied again after suppression at the first time

### 6.3 Engineer parameter (PASS-0202 menu)

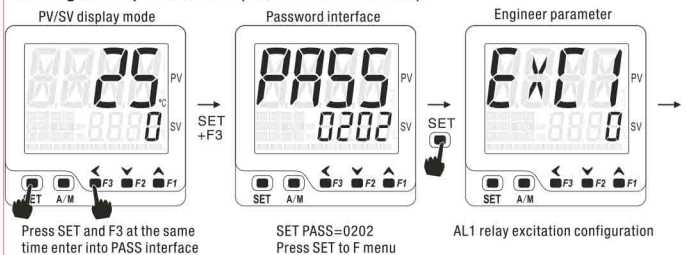

#### Engineer parameters menu "0202"(PASS-0202)

Notation	Name	Range	Default	Remark
EXC1	AL1 relay excitation	0,1	0	0: AL1 relay pull-in when alarm 1 triggered 1: AL1 relay release when alarm 1 triggered
AIL1	AL1 interlock	0,1	0	0: AL1 output standard mode 1: AL1 output interlock mode
EXC2	AL2 relay excitation	0,1	0	0: AL2 relay pull-in when alarm 2 triggered 1: AL2 relay release when alarm 2 triggered
AIL2	AL2 interlock	0,1	0	0: AL2 output standard mode 1: AL2 output interlock mode

#### 6.3.1 Alarm interlock disengaged procedure

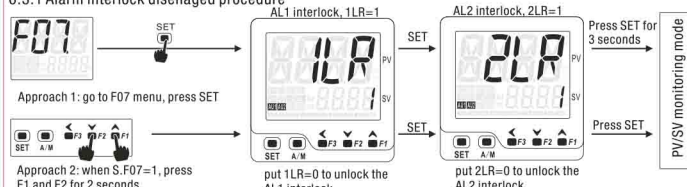

### 6.4 Engineer parameter menu 3 (PASS-0303 menu)

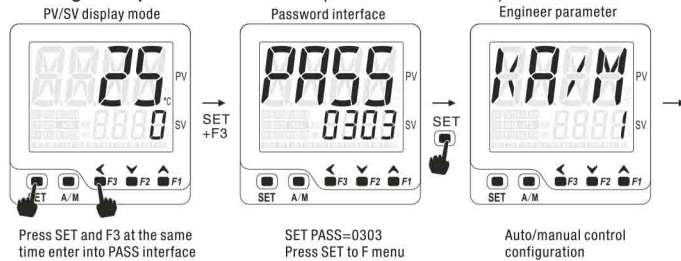

Depends on the specific functions some of parameter may or may not be available

Notation	Name	Range	Factory default	Remark
KRAM	Auto/manual control switch configuration	0,1	1	0: A/M key disabled 1: A/M Key enable (press A/M key 3 seconds to switch)
KR/S	Run/Stop function configuration	0,1	0	0: Disable RUN function active by F1 key 1: Enable RUN function active by F1 key 2: Disable STOP function active by F2 key 3: Enable STOP function active by F2 key
KALU	Auto-tuning short cut key	0,1	0	0: Disable auto-tuning active by F3 key 1: Enable auto-tuning active by F3 key
PWON	Power on control mode	0,1,2,3	0	0: Auto control mode after power on 1: Stop mode after power on 2: Manual control mode after power on 3: Controller continue the status from where it left off
SFSL	soft-start function configuration	0,1	0	0: Disable soft-start function 1: Enable soft-start function
TR/S	Re-transmission configuration	0,1	0	0: PV re-transmission 1: SV re-transmission
PFbk	Position feedback configuration	0,1	0	0: Position feedback disabled 1: Position feedback enable for close loop control
RESV	Remote SV	0,1	0	0: Remote SV off 1: Remote SV on (panel SV setting off) 2: Remote SV on (panel SV setting on)
MAN1	Quick start menu 1 configuration	0,1,2,3	1	0: MV1, MV2, MVFb absent in quick menu 1 1: MV1, MV2, present in quick menu 1, MVFb absent 2: MVFb present in quick menu 1, MV1, MV2 absent 3: MV1, MV2, MVFb present in quick menu 1
BERM	Bar graphic display configuration	0,1,2,3	0	0: Bargraphic for OP1 % 1: Bargraphic for OP2 % 2: Bargraphic for TRS % 3: Bargraphic for MVFb %
ETUN	Timer unit	0,1	0	0: Timer unit " second" 1: Timer unit " minute"
REMS	manual output % remote setting	0,1	0	0: Manual output % set via key pad 1: Manual output % set via remote signal

Three approaches to exist and save the configuration under F menu

- 1: Press SET key for 3 seconds
- 2: Quick press A/M key once
- 3: Press SET and F3 at the same time

### 7. Auto-Tuning

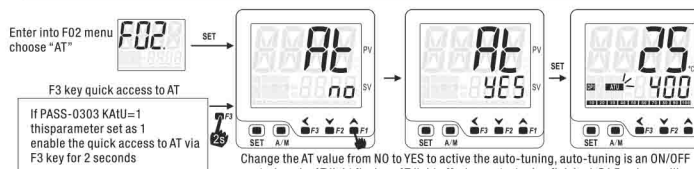

Configure the ATVL parameter under F04 menu, the SV can be shifted down to prevent large overshoot during the auto-tuning. Auto-tuning will be terminated if you enter into manual mode or STOP mode or encounter a power interruption. Auto-tuning will be terminated if the AT value change from YES to NO during the auto-tuning process. Under remote SV pattern, the SV will be locked if auto-tuning activated, the auto-tuning SV will be the SV when it was locked, recommend to switch to panel SV setting mode before auto-tuning. \*Please start the auto-tuning at the ambient temp to get best auto-tuning result

### 8. Auto manual control switch

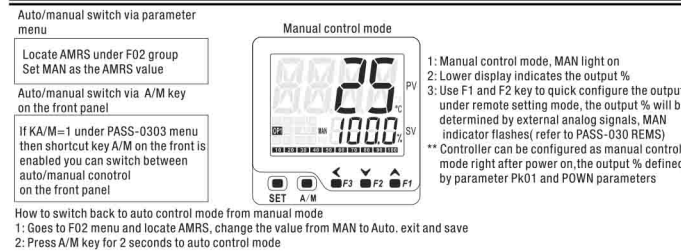

### 9. RUN/STOP function

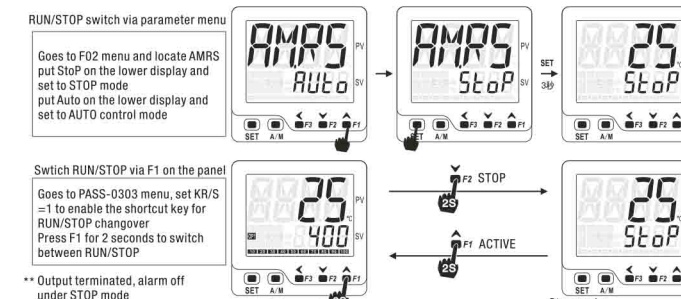

## 10. SV Panel setting and remote setting

### 10.1 Remote setting SV, use D1/D2 terminals at the back to set the SV

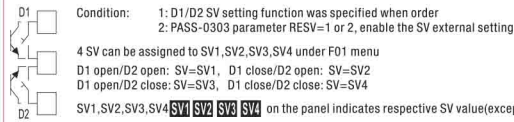

### 10.2 Remote setting SV via external analog signal input from INP2 or INP3

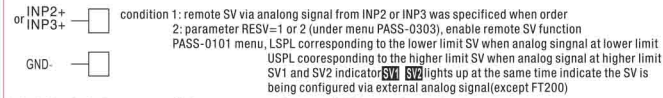

### 10.3 Switch between SV remote setting and SV panel setting

Go to PASS-0303 and set RESV=2, quick switch between remote SV setting and panel SV setting enabled, enter into remote SV mode after power on

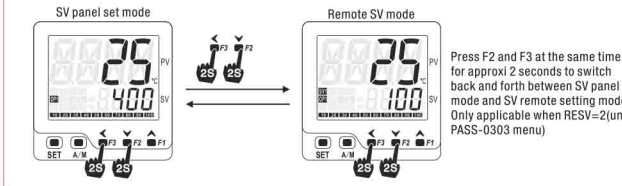

## 11. Three wires motor valve control

This is only available for valve control version of controller  
please specify if you need position feedback or not when order with us, output: OP1 for valve direct acting (open), OP2 for valve reverse acting(close), make sure to put the motor valve on the intermediate relay or AC contractors, You can also go to PASS-0303 and set PFBK=0 and switch off the position feedback function in case you've already ordered a controller with position feedback feature, the motor valve travel time must be specified via RUCY parameter under PASS-0101 menu in a no position feedback case, Quick start menu parameter MVFB is a monitoring parameter for the valve feedback value, this can be configured via parameter MoNI under PASS-0303, the bargraphic can also be used to indicate the feedback value, this can be configured via bEAM under PASS=0303

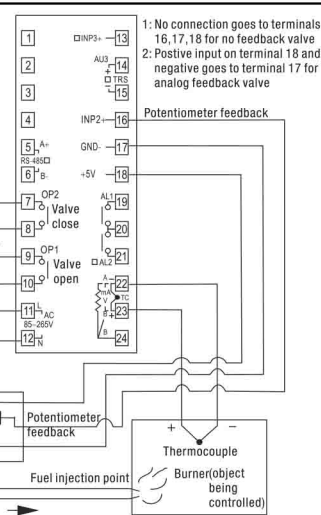

## 12. Position feedback calibration and operation

Condition  
1: Position analog feedback via terminal INP2 ordered( only applicable for 3 wires motor valve or analog output controller)  
2: PFBK=1, position feedback enabled for close loop control  
General feedback signal, 1) standard analog signal, 2)Potentiometer feedback signal, specify when order

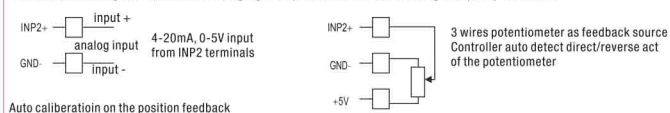

Auto calibration on the position feedback

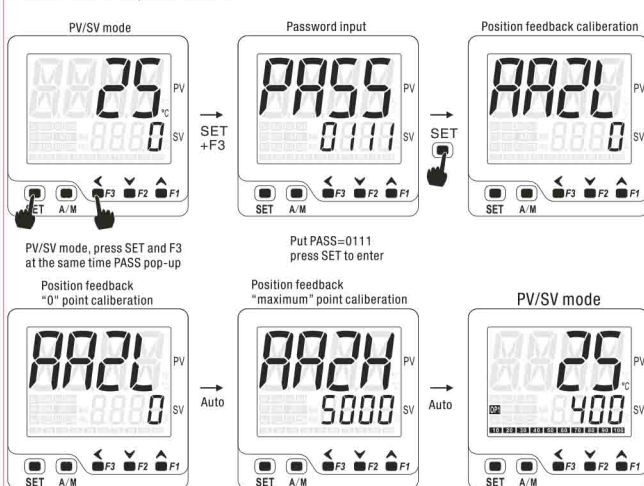

1. 3 wires motor valve auto calibration  
Upper shows AA2L, OP1 light on, OP1 relay pull-in, valve direct act lower display changes along with the direct act, display switch to the right one after some while, calibration finished

2. Analog output controller  
upper shows AA2L, OP1 output at 0% value, lower display changes along with the feedback signal, display switch to the one at right after some while, "0" calibration finished

1. Upper shows AA2H, OP1 light on, OP1 relay pull-in, valve direct act lower display changes along with the direct act, display switch to the right one after some while, calibration finished

2. For analog output, upper shows AA2H, OP1 output 100%, lower display changes along with the valve feedback signal, display changes to the right after some while, process finished

Calibration finish, goes back to PV/SV mode, these process always carried out automatically, user shall only observe the lower display changes, MVFB can be used to monitor the feedback value, MoNI under PASS-0303 used to define the status of MVFB  
Bargraphic % display can be used to shows the feedback %, bEAM under PASS-0303 used to define the status of the bargraphic display

## 13. Temp constant mode and ramp/soak mode

This is only applicable for programmable version of controller, specify when order

### 13.1 Parameters that involved

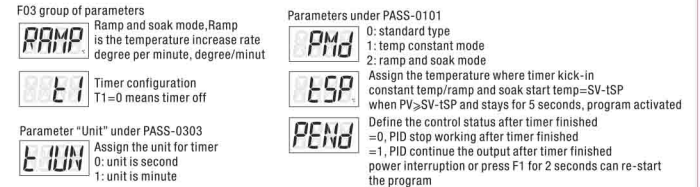

### 13.2 Ramp and soak mode detailed working flow chart PMd=2

1. program execute: power-on, lower display shows SV, this will delay 5 seconds before the program starts, PRG lights on during the ramp and soak process, lower display starts to indicate the PV value, PV increase gradually based on the preset ramp up rate towards to SV value  
2. Timer kick-in: When PV > SV-ISP for 5 seconds, timer kick-in, lower display shows the timer, PRG flashes, timer range is t1 value, timer starts alarm and timer finish alarm can be configured, refer to PASS-0101 ALd1 and ALd2  
3. Timer finish: when timer finish, PRG light on, based on PENd parameter under PASS-0101, output can be configured as continue working or stop, when alarm mode=18, alarm will be triggered after timer finish  
4. program terminated: if PENd=0 configured, program ends after timer finish, lower display shows "End" main output off, press F1 for 2 seconds can enter into STOP mode or active the program again

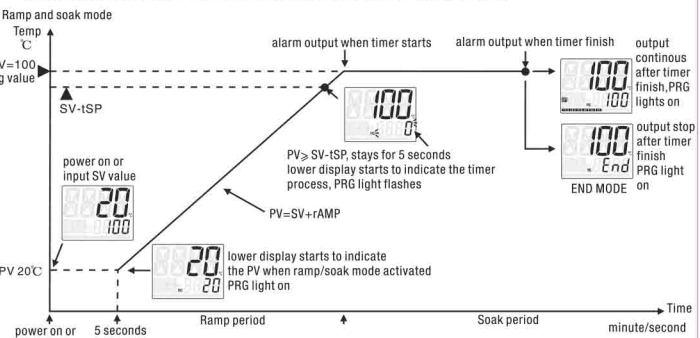

### 13.3 Temp constant mode working flow chart PMd=1

1. Program activate: lower shows SV, and heatup towards SV immediately  
2. Timer kick-in: when PV > SV-ISP, stays for 5 seconds, timer activated, lower display shows timing process, PRG flashes, timer range is t1 value, an alarm can go off when timers starts by configuring the ALd1 or ALd2=17 under PASS-0101  
3. Timer finish: when timer finish, PRG light on, based on PENd parameter under PASS-0101, output can be configured as continue working or stop, when alarm mode=18, alarm will be triggered after timer finish  
4. program terminated: if PENd=0 configured, program ends after timer finish, lower display shows "End" main output off, press F1 for 2 seconds can enter into STOP mode or active the program again

## 14. RS-485 communication brief

- (1) Communication based on modbus RTU, support 03 read command, 06 and 10 write command
- (2) Communication format, 2 wires system, half-duplex, single drop connection
- (3) Communication speed: 2400, 4800, 9600, 19200 baud rate, data format, 1 start bit+ 8 data bit+parity(N, o, E)+1 /2 stop bit
- (4) Support maximum 36 write command and 37 read command
- (5) Detailed setting goes to PASS-0101 and locate parameter Idn0, bAUd, UCR parameters
- (6) Refer to "COM-800-C1" for detailed communication protocol information

## 15. Input sensors and range

Input type	Code	Input type	Code
K	0.0 to 200.0 °C	K	D2
	0.0 to 400.0 °C	K	D4
	0 to 400 °C	K	A4
	0 to 600 °C	K	A6
E	0 to 1300 °C	K	B3
	0.0 to 200.0 °C	E	D2
	0.0 to 300.0 °C	E	D3
	0 to 200 °C	E	A2
J	0 to 400 °C	E	A4
	0 to 800 °C	E	A8
	0.0 to 300.0 °C	J	D3
	0.0 to 400.0 °C	J	D4
T	0 to 300 °C	J	A3
	0 to 400 °C	J	A4
	0 to 1000 °C	J	A0
	0 to 300 °C	T	D4
S **	0 to 1600 °C	S	B6
	0 to 1769 °C	R	B8
R	200 to 1800 °C	B	B8
	0 to 1300 °C	N	B3
Wu3_Re25	600 to 2200 °C	W	B0
Pt100	0.0 to 100.0 °C	D	D1
	0.0 to 200.0 °C	D	D2
	-50.0 to 200.0 °C	D	G2
	-100.0 to +200.0 °C	D	F2
	-199.9 to +200.0 °C	D	F3
	0 to 100 °C	D	A1
	0 to 200 °C	D	A2
	0 to 400 °C	D	A4
	0 to 800 °C	D	A8
	-100 to 200 °C	D	C2
-200 to 400 °C	D	C4	
-200 to 600 °C	D	C6	
-200 to 800 °C	D	C8	
Input type		Code	
AN1 0 to 50mV	-1999 to 9999	V	02
AN2 10 to 50mV	-1999 to 9999	V	10
AN3 0 to 5VDC	-199.9 to 999.9	V	03
AN3 0 to 10VDC	-199.9 to 999.9	V	04
AN4 1 to 5VDC	-19.99 to 99.99	V	08
AN4 2 to 10VDC	-19.99 to 99.99	V	09
AN4 4 to 20mA	-1.999 to 9.999	A	03
AN3 0 to 20mA		A	02
AN3 0 to 10mA		A	01

The accuracy is not guaranteed for type S thermocouple in the range of 0-100

Remark 1: user can switch input between thermocouple and RTDs via software

Remark 2: analog input except 0-50mA, 10-50mV needs to be specified when order